



XEBEC TECHNOLOGY CO.,LTD.
Fuerte Kojimachi1-7 Building 4F, 1-7-25 Kojimachi,
Chiyoda-ku, Tokyo, 102-0083, Japan
TEL: +81-3-3239-3481 FAX: +81-3-5211-8964
www.xebec-tech.com
info@xebec-tech.co.jp

 / XEBEC TECHNOLOGY English



 LinkedIn



2022.10.1000at



XEBEC TECHNOLOGY
Product Catalog
2022 / 2023

BEAUTIFUL DEBURRING®

XEBEC TECHNOLOGY CO.,LTD.

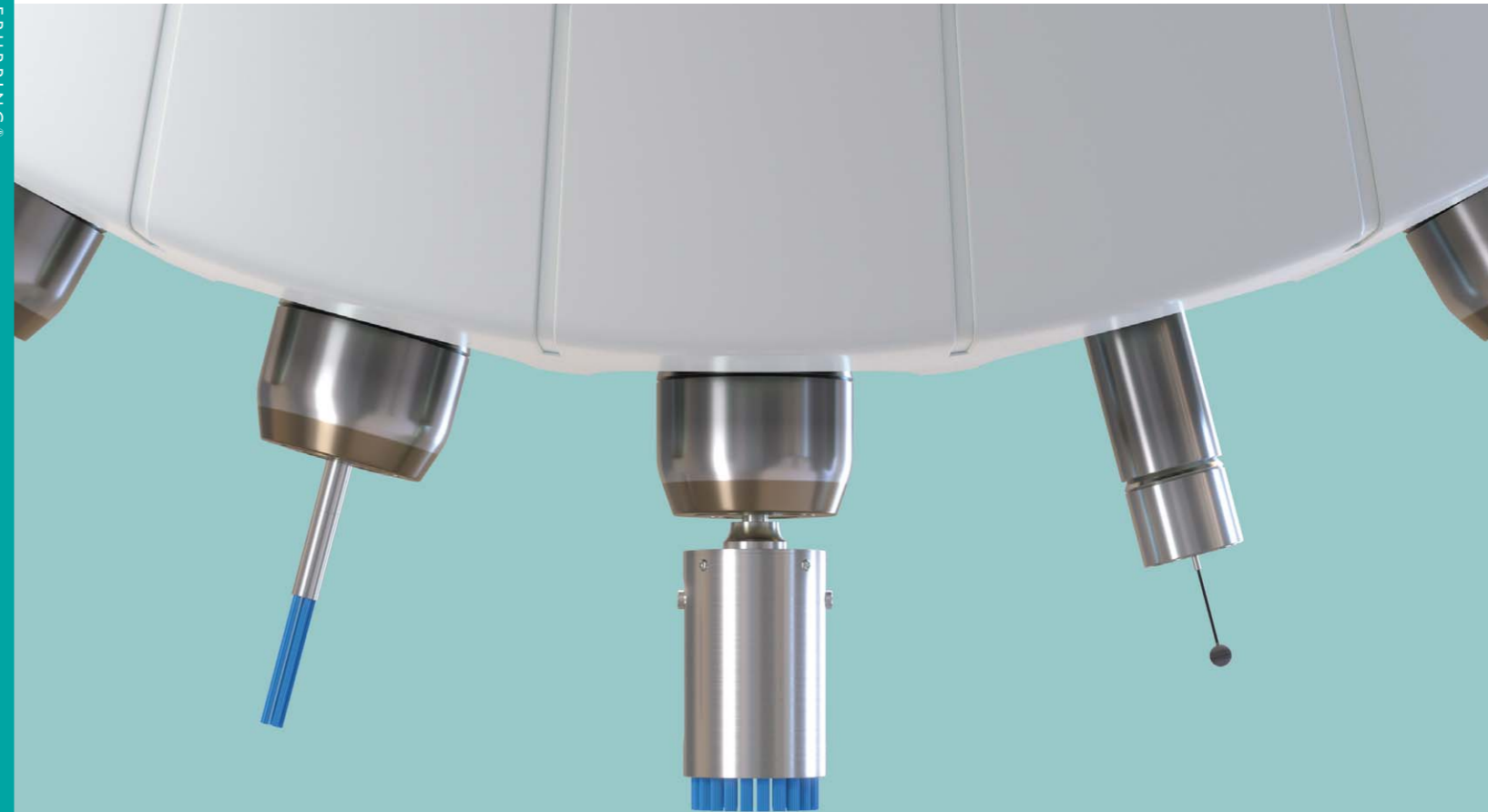

BEAUTIFUL DEBURRING®

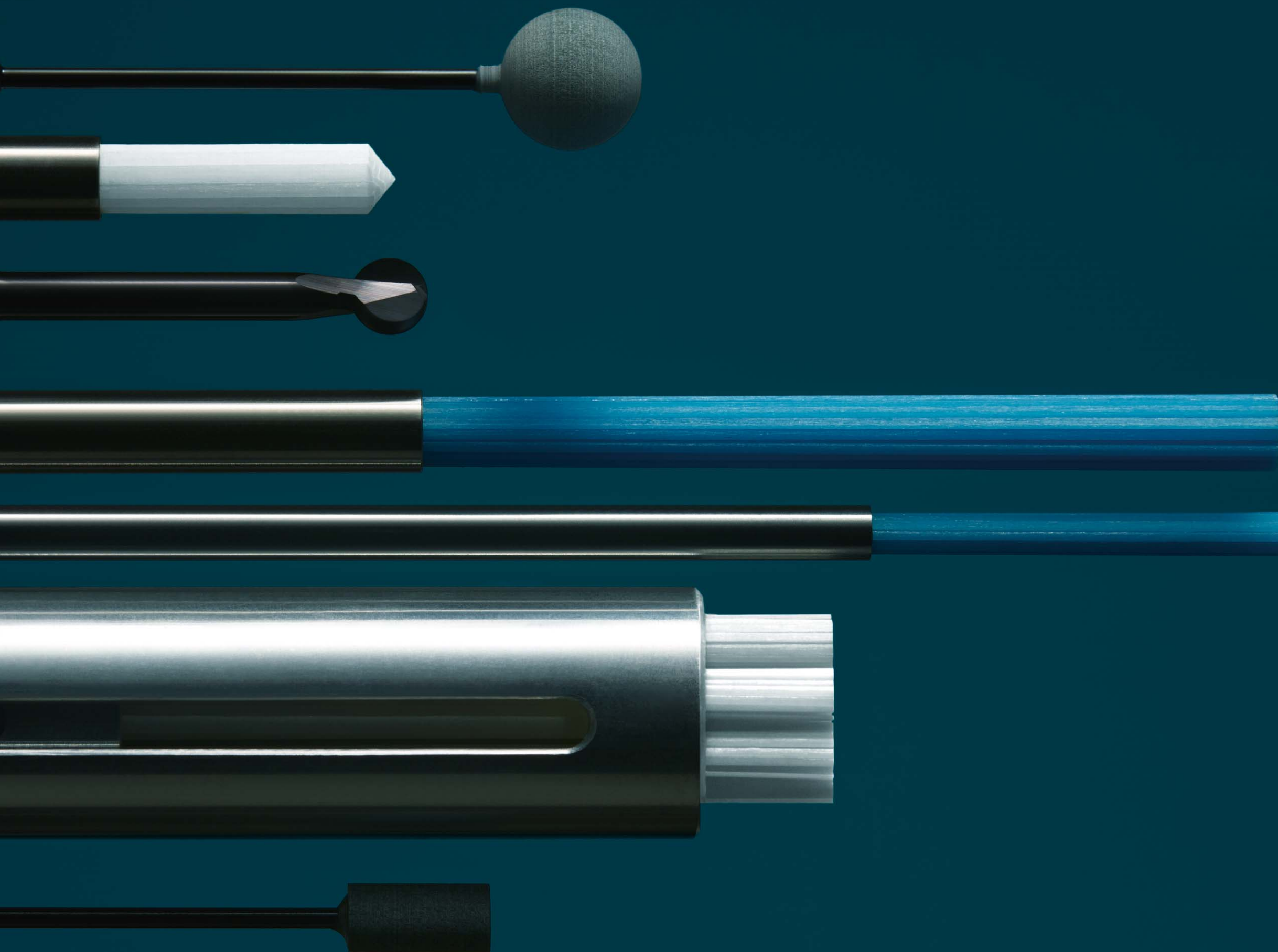

INDEX

Applications	03
XEBEC Brush™	05
XEBEC Brush™ Surface	07
XEBEC Brush™ Surface End Type	09
XEBEC Brush™ Surface Extra-Large	10
XEBEC Brush™ Crosshole	11
XEBEC Brush™ Crosshole Extra-Large	13
XEBEC Brush™ Crosshole Extra-Long	14
XEBEC Brush™ Wheel Type	15
XEBEC Optional Tools	17
XEBEC Floating Holder™	19
XEBEC Self-Adjusting Tool™	21
XEBEC Short BT Holder™	23
XEBEC Brush Length Adjustment Tool™	23
XEBEC Back Burr Cutter and Path™	25
XEBEC Back Burr Cutter™	27
XEBEC Path™	29
XEBEC Ceramic Stone™	31
XEBEC Stone™ Flexible Shaft	33
XEBEC Stone™ Mounted Point	35
Mobile Micromotor System	37
Technical information	38
About XEBEC	45
History	46

Automotive

CNC deburring of cylinder head

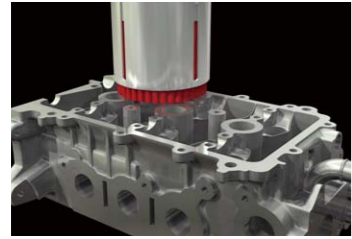

Material : ADC12
Previous process : Face milling
Tool : XEBEC Brush Surface
(P. 7)
A11-CB100M



[Video \(YouTube\)](#)

CNC deburring of inverter case



Material : ADC12
Previous process : Face milling
Tool : XEBEC Brush Surface
(P. 7)
A32-CB25M



[Video \(YouTube\)](#)

CNC removal of film coating on combustor part



Material : Ceramics
Previous process : Face milling
Tool : XEBEC Brush Surface
(P. 7)
A11-CB15M



[Video \(YouTube\)](#)

CNC deburring of input shaft

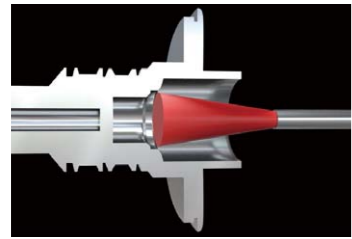

Material : SCM
Previous process : Drilling
Tool : XEBEC Brush Crosshole
(P. 11)
CH-A12-7M-TL



[Video \(YouTube\)](#)

Manual polishing of tire mold



Material : Aluminum
Previous process : Ball end milling
Tool : XEBEC Brush Surface
End Type(P. 9)
A11-EB06M



[Video \(YouTube\)](#)

CNC deburring of differential case

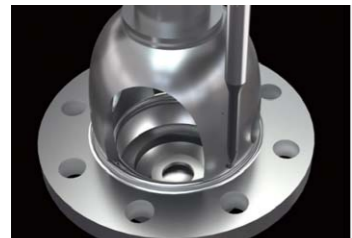

Material : FCD
Previous process: Drilling
Tool : XEBEC Back Burr Cutter
and Path (P. 27)
XC-78-A



[Video \(YouTube\)](#)

CNC deburring of scroll compressor



Material : Aluminum
Previous process : Face milling
Tool : XEBEC Brush Surface
(P. 7)
A11-CB40M



[Video \(YouTube\)](#)

CNC deburring of pinion gear

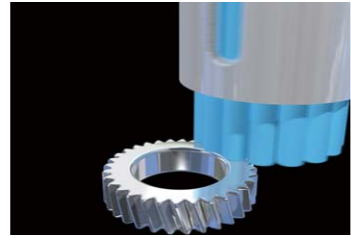

Material : S45C
Previous process : Gear hobbing
Tool : XEBEC Brush Surface
(P. 7)
A32-CB40M



[Video \(YouTube\)](#)

CNC polishing of metal mold for car body panel



Material : SKD11
Previous process : End milling
Tool : XEBEC Brush Surface
(P. 7)
A32-CB25M A11-CB25M



[Video \(YouTube\)](#)

CNC deburring of yoke



Material : SCM
Previous process : Drilling
Tool : XEBEC Back Burr Cutter
and Path (P. 27)
XC-58-A



[Video \(YouTube\)](#)

CNC deburring of camshaft

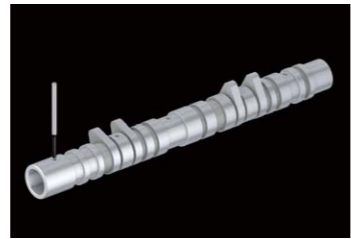

Material : FCD
Previous process : Drilling
Tool : XEBEC Back Burr Cutter
and Path (P. 27)
XC-38-A



[Video \(YouTube\)](#)

Industrial Machinery

CNC deburring of gearbox



Material : FC250
Previous process : Face milling
Tool : XEBEC Brush Surface
(P. 7)
A32-CB60M



[Video \(YouTube\)](#)

CNC deburring of slide cylinder



Material : Aluminum
Previous process : End milling
Tool : XEBEC Brush Surface
(P. 7)
A21-CB25M



[Video \(YouTube\)](#)

CNC roughing of brake disc

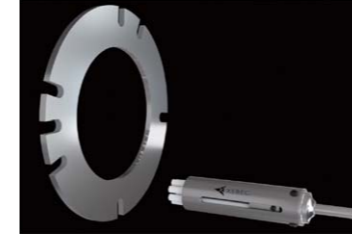

Material : SPHC
Previous process : Turning
Tool : XEBEC Brush Surface
(P. 7)
A21-CB25M



[Video \(YouTube\)](#)

Areospace

CNC polishing of turbine blade

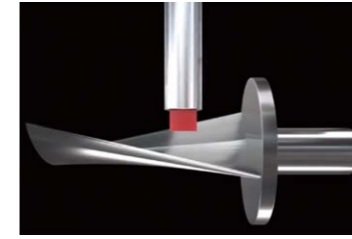

Material : SUS630
Previous process : Ball end milling
Tool : XEBEC Brush Surface
(P. 7)
A32-CB25M A11-CB25M



[Video \(YouTube\)](#)

Manual deburring of hydraulic manifold



Material : Aluminum
Previous process : Drilling
Tool : XEBEC Stone Flexible
Shaft (P. 33)
CH-PM-6B



[Video \(YouTube\)](#)

Manual deburring of shaft



Material : Aluminum
Previous process : Casting
Tool : XEBEC Stone Mounted
Point (P. 35)
AX-PM-6T



[Video \(YouTube\)](#)

CNC deburring of pipe

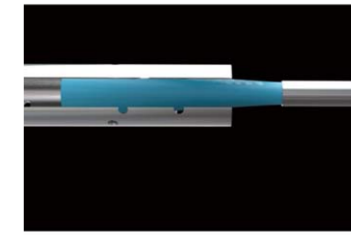

Material : SUS
Previous process : Drilling
Tool : XEBEC Brush Crosshole
(P. 11)
CH-A33-7M



[Video \(YouTube\)](#)

CNC deburring of shaft



Material : SCM
Previous process : Threading
Tool : XEBEC Brush Wheel
Type (P. 15)
W-A11-50



[Video \(YouTube\)](#)

Orthopedic Medical Devices

CNC polishing of artificial hip joint



Material : CoCrMo
Previous process : Turning
Tool : XEBEC Brush Surface
(P. 7)
A13-CB06M



[Video \(YouTube\)](#)

CNC deburring of osteosynthesis screw



Material : Titanium
Previous process : End milling
Tool : XEBEC Brush Surface
End Type (P. 9)
A11-EB06M



[Video \(YouTube\)](#)

CNC deburring of spinal implant



Material : PEEK resin
Previous process : End milling
Tool : XEBEC Back Burr Cutter
and Path (P. 27)
XC-18-A



[Video \(YouTube\)](#)

Automate deburring and polishing in your CNC machine

XEBEC Brush™

“Is there any way to apply the technology of ceramic stone to a brush? It would be a game-changer”
 XEBEC Brush came into being through a pure eagerness to take on engineering challenges, even when exact uses were yet to be discovered. Together with innovative customers who recognized the possibilities of this unique product, we discovered its value; the ability to deburr and improve surface roughness at the same time, with consistencies that were not conceivable with conventional tools. These findings inspired us to pioneer the concept of automation of deburring and polishing.

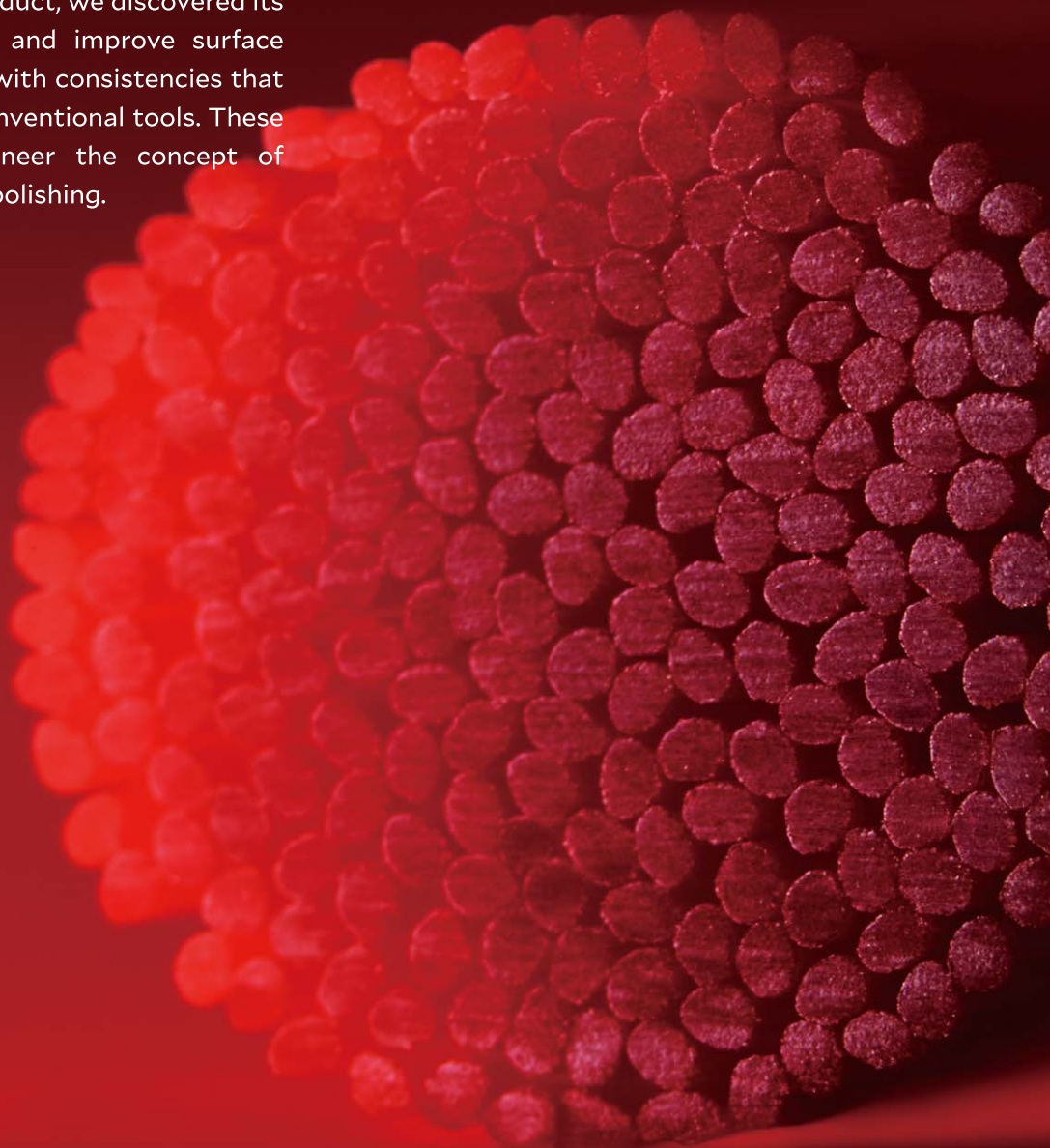

XEBEC Brush uses unique abrasive ceramic fiber material instead of abrasive grain. Each bristle consists of 1,000 ceramic fibers that work as cutting edges. Overwhelming grinding power, Consistent cutting performance, No deformation. Enables CNC deburring immediately after milling and machining operations inside the same machine tool.

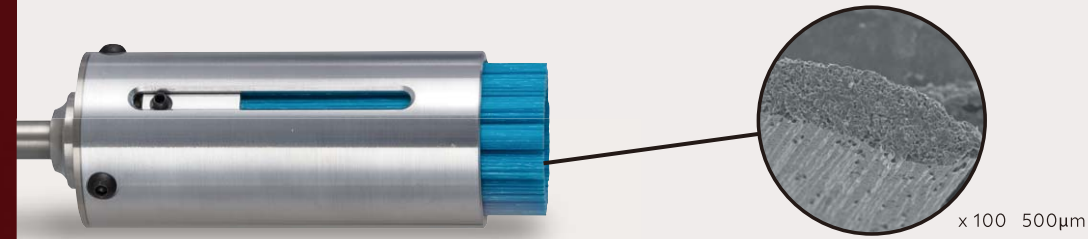

Grinding power

The content ratio of ceramic fiber is approximately 80%. Cutting edges on the Brush tips offer excellent grinding power.

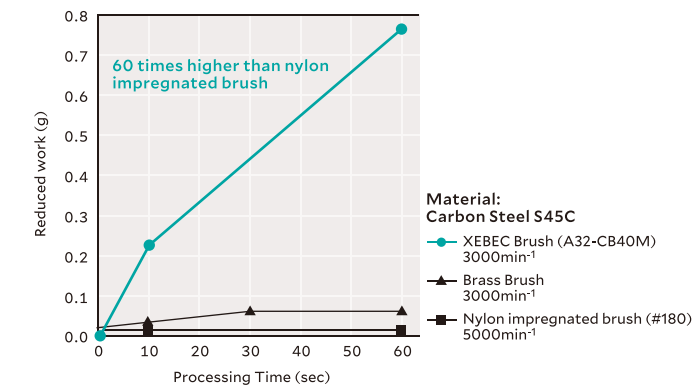

Consistent cutting performance

New cutting edges always exposed. Consistent cutting performance to the end thanks to the structure of the continuous fiber.

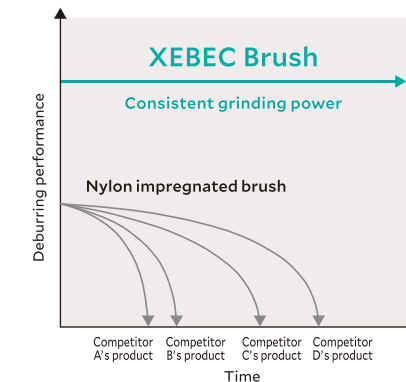

No deformation

Maintains its straight shape and does not spread out like a toothbrush. Easy to manage on mass production lines.

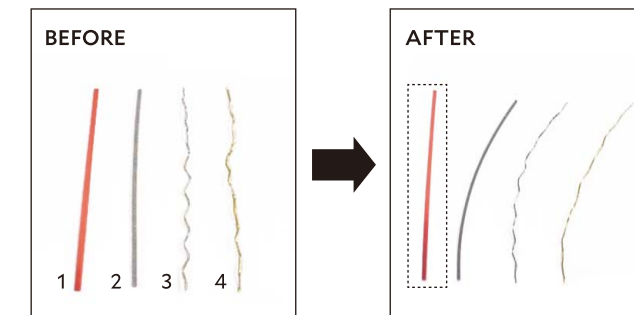

1. XEBEC Brush (A11 Red bristle)
2. Abrasive impregnated nylon brush
3. Steel wire brush
4. Brass wire brush

Optimal for polishing

Overwhelming grinding power of ceramic fibers makes this an optimal polishing tool. Achievable surface roughness Ra=0.1µm(Rz=0.4µm)

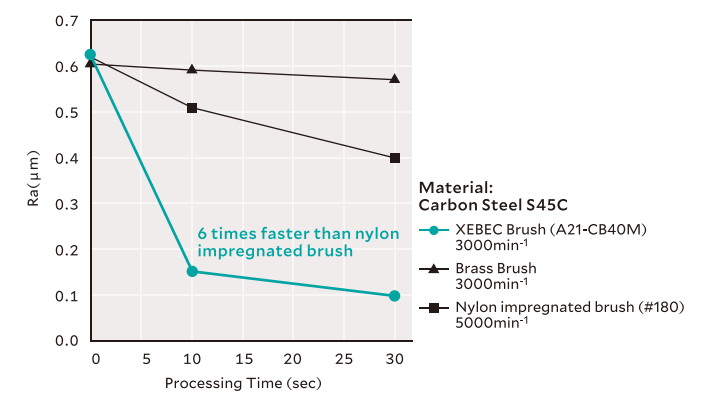

How to select the Brush color

Workpiece material	Resin	Copper, Brass			
		Aluminum			
Thickness of burrs	Micro fine burrs	Burr root thickness (~0.1mm)		Burr root thickness (0.1~0.2mm)	
		General steel			
		Stainless steel			
		Heat-resistant steel			
Brush (Color)	A13(Pink)	A11(Red)	A21(White)	A32(Blue)	Hard-to-cut material
	Grinding power → High				

*Available Brush colors are different depending on the Brush size.

Deburring



Polishing

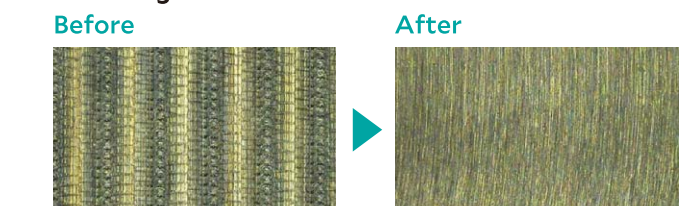

XEBEC Brush™ Surface Patented

Ideal for deburring, cutter mark removal and surface polishing

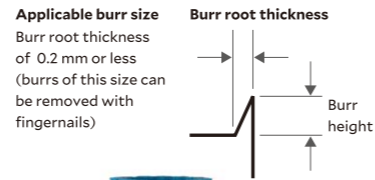

[Video \(YouTube\)](#)

Applications

Deburring automation with high consistency

Cylinder Head



Material : Aluminum
Previous process : Face milling
Tool : A11-CB100M

Before

Abrasive impregnated nylon brush was used. It was time-consuming and not effective enough to remove all burrs.

After

All burrs are removed by high grinding power. Quality is stabilized. The cycle time is shortened by high feed rate.

Polishing Automation

Metal Mold



Material : Hard-to-cut material
Previous process : End milling
Tool : A11-CB25M

Before

40 minutes manual polishing per workpiece. Received complaints from customers for uneven quality.

After

Shortened the polishing time to one minute per workpiece by automation. Improved and uniform polishing quality.

Tool composition

Brush and Sleeve are sold separately.
Assemble Brush and Sleeve before use.



Applicable equipment

This tool can be mounted on equipment shown below:

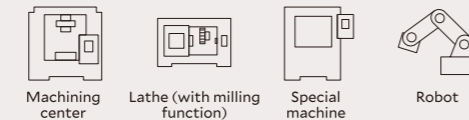

Brush

Brush (Color)	Product code	Brush diameter (mm)	Bristle length ℓ (mm)	Matching Sleeve	Fig
A13 (Pink)	A13-CB06M	φ 6	30	S06M	1
	A13-CB15M	φ 15	50	S15M-P	1
A11 (Red)	A11-CB06M	φ 6	30	S06M	1
	A11-CB15M	φ 15	50	S15M-P	1
	A11-CB25M	φ 25	75	S25M	1
	A11-CB40M	φ 40	75	S40M-SD10	1
	A11-CB60M	φ 60	75	S60M	1
	A11-CB100M	φ 100	75	S100M	1
A21 (White)	A21-CB06M	φ 6	30	S06M	1
	A21-CB15M	φ 15	50	S15M-P	1
	A21-CB25M	φ 25	75	S25M	1
	A21-CB40M	φ 40	75	S40M-SD10	1
	A21-CB60M	φ 60	75	S60M	1
A32 (Blue)	A32-CB06M	φ 6	30	S06M	1
	A32-CB15M	φ 15	50	S15M-P	1
	A32-CB25M	φ 25	75	S25M	1
	A32-CB40M	φ 40	75	S40M-SD10	1
	A32-CB60M	φ 60	75	S60M	1
	A32-CB100M	φ 100	75	S100M	1

* Bristle bundles are embedded in line on the periphery (except for the A13/A11/A21/A32-CB06M).
* The Brush size is approximate as the tip expands by rotating.
* Brushes with the diameter larger than φ100 are available by special orders. Please refer to the page 10.

Sleeve

Product code	Brush diameter (mm)	External diameter Dc (mm)	Shank diameter Ds (mm)	Overall length L (mm)	Shank length ℓs (mm)	Matching Brush	Fig
S06M	φ 6	φ 10	φ 6	70	29	A13/A11/A21/A32-CB06M	2
S15M-P	φ 15	φ 18.5	φ 6	90	29	A13/A11/A21/A32-CB15M	2
S25M	φ 25	φ 30	φ 8	140	30	A11/A21/A32-CB25M	2
S40M-SD10	φ 40	φ 45	φ 10	140	30	A11/A21/A32-CB40M	2
S60M	φ 60	φ 65	φ 12	150	35	A11/A21/A32-CB60M	2
S100M	φ 100	φ 110	φ 16	162	40	A11/A21/A32-CB100M	2

*When in use, the length of the brush projection is added to the overall length of a sleeve.
*The external cylinder of the S15M-P is made of Fiber-Reinforced Plastic (FRP).

[See P.39 to select Brush color](#)

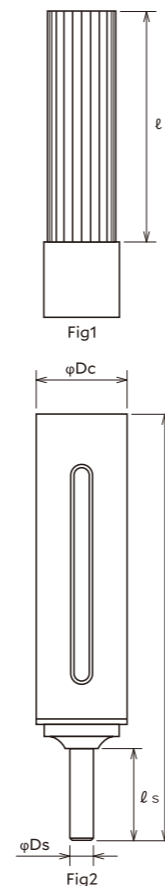

How to use

Processing conditions

Rotational speed

Recommended parameters differ depending on the Brush size.
Refer to the chart below for the standard machining conditions of each Brush size.

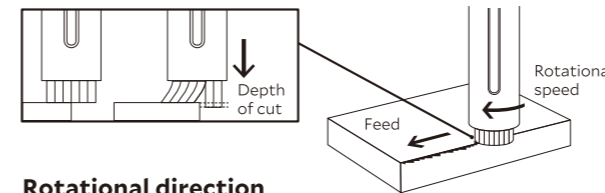

Rotational direction

Set the rotational direction so that the Brush pushes upward against the burrs from the bottom.

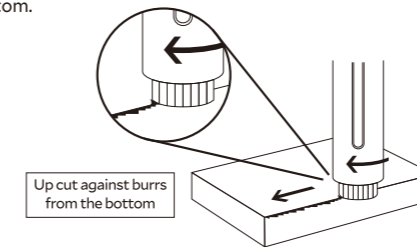

Feed rate

Burr root thickness (removable with fingernails)	0.05mm (Can be bent easily)	→	4000mm/min
	0.1mm (Can be bent)	→	2500mm/min
Cutter mark removal, polishing		→	250 - 850mm/min

Depth of cut

Vertical burrs	Burrs that are formed while end milling and drilling. Vertical to the Brush tip.	→	0.5mm
Horizontal burrs	Burrs that are formed while face milling. Parallel to the Brush tip.	→	1.0mm
Cutter mark removal, polishing		→	0.3 - 0.5mm

Machining Parameters

Standard Machining Parameters

Product code	Rotational speed (min ⁻²)			Depth of cut (mm)			Feed rate (mm/min)			Brush projection (mm)	
	Deburring	Cutter mark removal, polishing	Maximum	Vertical burrs	Horizontal burrs	Cutter mark removal, polishing	Burr root thickness 0.05mm	Burr root thickness 0.1mm	Cutter mark removal, Polishing	Deburring	Cutter mark removal, Polishing
A13-CB06M, A11-CB06M, A21-CB06M	8000	10000	10000	0.5	0.5	0.3	4000	2500	250	10	10
A32-CB06M	8000	10000	10000	0.3	0.3	0.3	4000	2500	250	10	10
A13-CB15M	4800	6000	6000	1.0	1.0	0.5	4000	2500	450	10	10
A11-CB15M, A21-CB15M, A32-CB15M	4800	6000	6000	0.5	1.0	0.5	4000	2500	450	10	10
A11-CB25M, A21-CB25M, A32-CB25M	4000	5000	5000	0.5	1.0	0.5	4000	2500	700	15	10
A11-CB40M, A21-CB40M, A32-CB40M	2400	3000	3000	0.5	1.0	0.5	4000	2500	800	15	10
A11-CB60M, A21-CB60M, A32-CB60M	1600	2000	2000	0.5	1.0	0.5	4000	2500	850	15	10
A11-CB100M, A21-CB100M, A32-CB100M	960	1200	1200	0.5	1.0	0.5	4000	2500	850	15	10

* Workpiece made of plastics may deform or discolor, depending on the material characteristics. If the workpiece deforms, reducing the rotational speed to approximately 10% of the standard machining condition may solve the problem.



[Instruction manual](#)

XEBEC Brush™ Surface End Type

Ideal for polishing and removing cutter marks on inner diameters and sealing surface

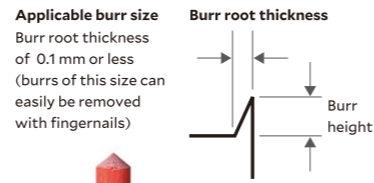

Applicable equipment

This tool can be used with rotary tools and equipments that can control the rotational speed.

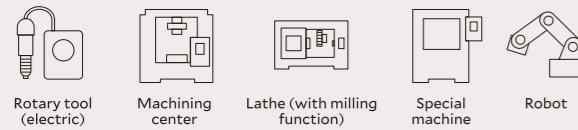

Brush

Brush (Color)	Product code	Brush diameter (mm)	Shank diameter Dc(mm)	Bristle length ℓ (mm)	Overall length L (mm)	Standard rotational speed (min ⁻¹)	Maximum rotational speed (min ⁻¹)	Fig
A13 (Pink)	A13-EB01S	φ 1	φ 3	15	52	7000 - 12000	15000	3
	A13-EB015S	φ 1.5	φ 3	15	52	7000 - 12000	15000	3
	A13-EB02S	φ 2	φ 3	15	52	7000 - 12000	15000	3
	A13-EB025S	φ 2.5	φ 3	15	52	7000 - 12000	15000	3
	A13-EB03M	φ 3	φ 3	30	67	4000	6000	3
A11 (Red)	A11-EB01S	φ 1	φ 3	15	52	7000 - 12000	15000	3
	A11-EB015S	φ 1.5	φ 3	15	52	7000 - 12000	15000	3
	A11-EB02S	φ 2	φ 3	15	52	7000 - 12000	15000	3
	A11-EB025S	φ 2.5	φ 3	15	52	7000 - 12000	15000	3
	A11-EB06M	φ 5	φ 3	20	57	7000	12000	4
A21 (White)	A21-EB06M	φ 5	φ 3	20	57	7000	12000	4
A32 (Blue)	A32-EB06M	φ 5	φ 3	20	57	7000	12000	4

*The Brush size is approximate as the tip expands by rotating.

Precautions for Use

The torque output of the rotary tool must be 2N or lower.

The Brush will break off if:

- used beyond the maximum rotational speed
- used beyond the maximum indentation load
- used with a pneumatic rotary tool

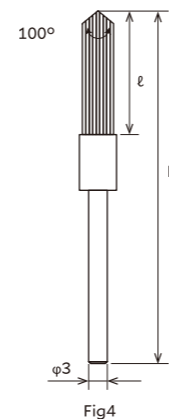
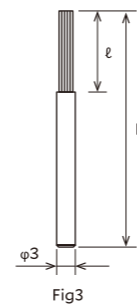

Fig4
(A11-EB06M
A21-EB06M
A32-EB06M)



Instruction manual

See P. 41 to select Brush color

XEBEC Brush™ Surface Extra-Large Patented

Ideal for deburring, cutter mark removal and surface polishing with a width of 100 mm or more

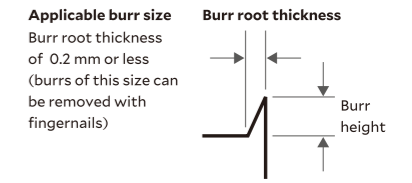
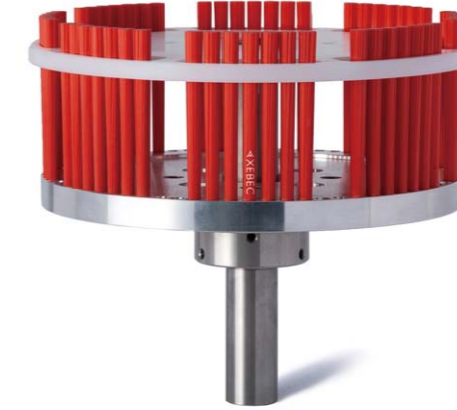

Tool composition

The brush main unit and the slide ring are separate items. Assemble the main unit and the slide ring before use.

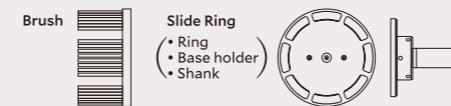

Applicable equipment

This tool can be mounted on equipment shown below:

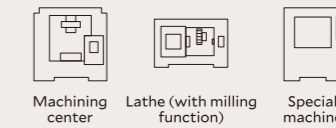

Brush

Brush (Color)	Product code	Brush diameter (mm)	Bristle length ℓ (mm)	Matching Slide Ring (Product code)	Fig
A11 (Red)	A11-CB125M	φ 125	75	SR125M	5
	A11-CB165M	φ 165	75	SR165M	5
	A11-CB200M	φ 200	75	SR200M	5
A21 (White)	A21-CB125M	φ 125	75	SR125M	5
	A21-CB165M	φ 165	75	SR165M	5
	A21-CB200M	φ 200	75	SR200M	5
A32 (Blue)	A32-CB125M	φ 125	75	SR125M	5
	A32-CB165M	φ 165	75	SR165M	5
	A32-CB200M	φ 200	75	SR200M	5

*The Brush size is approximate as the tip expands by rotating.

Slide Ring

Product code	Brush diameter (mm)	Outer diameter Dc (mm)	Shank diameter (mm)	Overall length L (mm)	Fig
SR125M	φ 125	φ 135	φ 25	187	5
SR165M	φ 165	φ 176	φ 25	187	5
SR200M	φ 200	φ 211	φ 25	187	5

*The Slide Ring consists of a ring, a base holder and a shank.

*Base holder and shank sizes are the same across all Brush diameter. Ring size varies by Brush diameter.

*The total weight of a Brush and a Slide Ring. φ125: 1920g, φ165: 2320g, φ200: 2750g

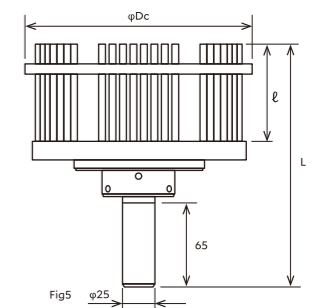

Machining Parameters

Standard Machining Parameters

Product code	Rotational speed (min ⁻¹)			Depth of cut (mm)			Feed rate (mm/min)			Brush projection (mm)	
	Deburring	Cutter mark removal, polishing	Maximum	Vertical burrs	Horizontal burrs	Cutter mark removal, polishing	Burr root thickness 0.05mm	Burr root thickness 0.1mm	Cutter mark removal, Polishing	Deburring	Cutter mark removal, Polishing
A11-CB125M, A21-CB125M, A32-CB125M	800	1000	1000	0.5	1.0	0.5	4000	2500	700	15	10
A11-CB165M, A21-CB165M, A32-CB165M	600	750	750	0.5	1.0	0.5	4000	2500	700	15	10
A11-CB200M, A21-CB200M, A32-CB200M	480	600	600	0.5	1.0	0.5	4000	2500	650	15	10

If you have trouble, please refer to P. 39 (XEBEC Brush Surface) for adjustment.



Instruction manual

See P. 39 to select Brush color

XEBEC Brush™ Crosshole

Ideal for deburring, polishing, and removing cutter marks on inner diameters and counterbores up to $\phi 20$

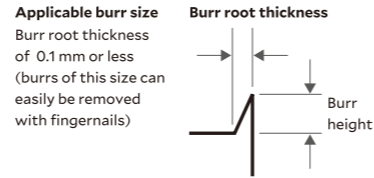

Video (YouTube)

Applicable equipment

This tool can be mounted on equipment which can control the rotational speed. The tool must be rotated over 6500 min^{-1} .

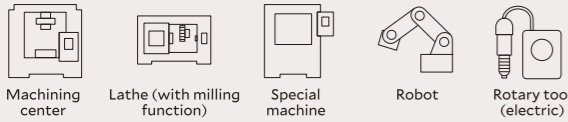

Brush (Color)	Product code	Brush diameter (mm)	Shank diameter D_c (mm)	Shank diameter D_s (mm)	Bristle length ℓ (mm)	Overall length L (mm)	Maximum rotational speed (min^{-1})	Target hole diameter (mm)	Fig
A12 (Red)	CH-A12-1.5M	$\phi 1.5$	$\phi 2.5$	$\phi 3$	50	120	20000	$\phi 3.5 - 5$	6
	CH-A12-3M-TL	$\phi 3$	$\phi 4$	$\phi 3$	50	120	14000	$\phi 5 - 8$	6
	CH-A12-3L-TL	$\phi 3$	$\phi 4$	$\phi 4$	50	170	12000	$\phi 5 - 8$	6
	CH-A12-5M-TL	$\phi 5$	$\phi 6$	$\phi 6$	50	120	14000	$\phi 8 - 10$	6
	CH-A12-5L-TL	$\phi 5$	$\phi 6$	$\phi 6$	50	170	12000	$\phi 8 - 10$	6
	CH-A12-7M-TL	$\phi 7$	$\phi 8$	$\phi 6$	50	120	14000	$\phi 10 - 20$	6
	CH-A12-7L-TL	$\phi 7$	$\phi 8$	$\phi 8$	50	170	12000	$\phi 10 - 20$	6
	CH-A12-11M	$\phi 11$	$\phi 12$	$\phi 12$	50	120	14000	$\phi 14 - 20$	6
A33 (Blue)	CH-A12-11L	$\phi 11$	$\phi 12$	$\phi 12$	50	170	12000	$\phi 14 - 20$	6
	CH-A33-3M	$\phi 3$	$\phi 4$	$\phi 3$	60	130	14000	$\phi 5 - 8$	6
	CH-A33-3L	$\phi 3$	$\phi 4$	$\phi 4$	60	180	12000	$\phi 5 - 8$	6
	CH-A33-5M	$\phi 5$	$\phi 6$	$\phi 6$	60	130	14000	$\phi 8 - 10$	6
	CH-A33-5L	$\phi 5$	$\phi 6$	$\phi 6$	60	180	12000	$\phi 8 - 10$	6
	CH-A33-7M	$\phi 7$	$\phi 8$	$\phi 6$	60	130	14000	$\phi 10 - 14$	6
	CH-A33-7L	$\phi 7$	$\phi 8$	$\phi 8$	60	180	12000	$\phi 10 - 14$	6
	CH-A33-11M	$\phi 11$	$\phi 12$	$\phi 12$	60	130	14000	$\phi 14 - 20$	6
CH-A33-11L	$\phi 11$	$\phi 12$	$\phi 12$	60	180	12000	$\phi 14 - 20$	6	

* The brush size is approximate as the tip expands by rotating.

Precautions for Use

The clamp length must be 30mm or more when attaching this tool on the machine, and make sure it is affixed rigidly.

The Brush will break off if:

- machined beyond the maximum rotational speed
- used with a pneumatic tool
- rotated outside the cylinder (outside workpiece)
- used with the tip of this tool is less than 20mm inside the bore

In the following cases, the Brush may break off:

- Off-center cross hole and angled cross hole
- T-shaped hole: If the cross hole diameter is 100% of the main bore diameter or more.
- Cross-shaped hole: If the cross hole diameter is 70% of the main bore diameter or more.

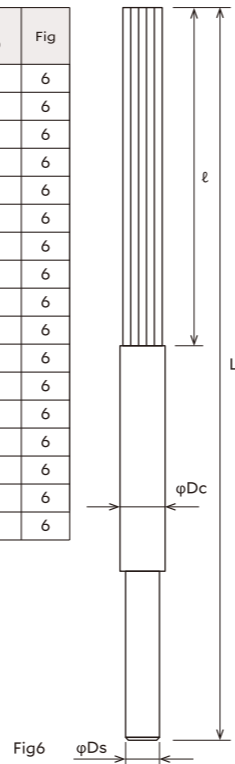

See P. 42 to select Brush color

Applications

Automation of cross hole deburring

Input Shaft

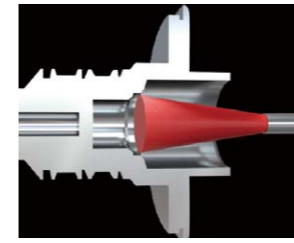

Material : SCM
Previous process : Drilling
Tool : CH-A12-7M-TL

Before

Deburring was done by manual work with abrasive impregnated nylon brush. Failed to remove all burrs with a low yield.

After

Realized automation of deburring with a special machine. All burrs are removed by high grinding power. Quality is stabilized.

Automation of cross hole deburring

Valve Case



Material : Resin
Previous process : Drilling
Tool : CH-A12-5M-TL

Before

Manual deburring with a cutter was time-consuming. Finished inner surface was scratched with the cutter and resulted in low quality.

After

Automated deburring inside the machine shortened the cycle time significantly. No scratches on the inner surface. Improved deburring quality.

How to use

For effective use

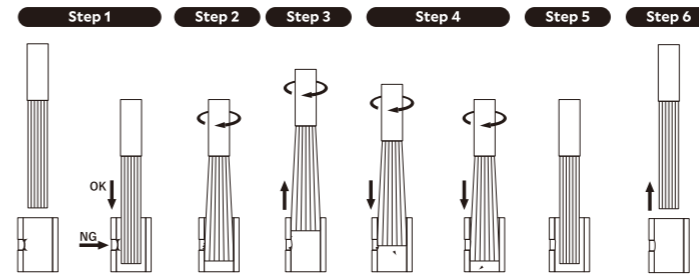

1. Insert the brush while not in motion.
*If you rotate the brush outside the cylinder, the bristles may be damaged or scattered and may cause injury to the operator.
2. Rotate the tool past the cross-hole
3. Process while pulling the brush back.
4. Process while pushing the brush forward.
5. Stop the brush rotation.
6. Remove the brush while it is at rest.

Machining Parameters

Adjusting the rotational speed

Optimize the performance of this Brush by adjusting the rotational speed depending on the Brush size, main bore diameter, and the Brush wear amount by referring to charts below. When the Brush is new, refer to the continuous line (—). When the Brush is worn by 10mm, refer to the dotted line (---).

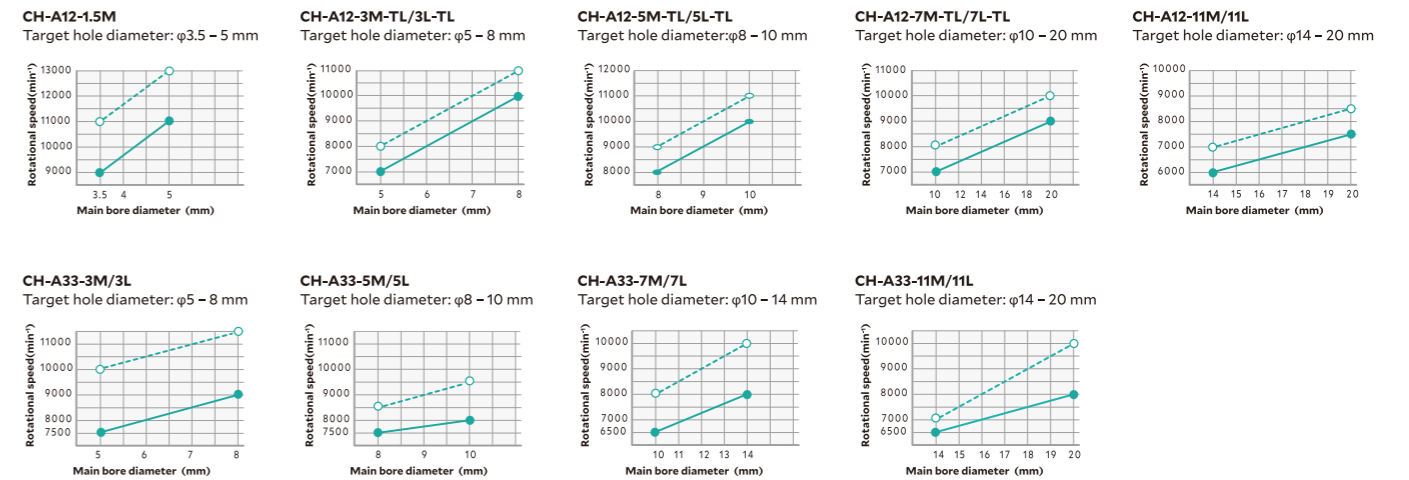

Feed rate

300 mm/min

Rotational direction

A uniform deburring and edge quality can be achieved by rotating the tool in both clockwise and counter-clockwise directions.



Instruction manual

XEBEC Brush™ Crosshole Extra-Large

Ideal for deburring, polishing, and removing cutter marks on inner diameters and counterbores between $\phi 20$ and $\phi 35$

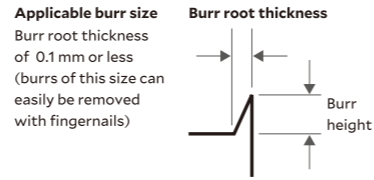

Video (YouTube)

XEBEC Brush™ Crosshole Extra-Long Patented

Ideal for deburring, polishing, and removing cutter marks on inner diameters and counterbores exceeding 150mm in depth

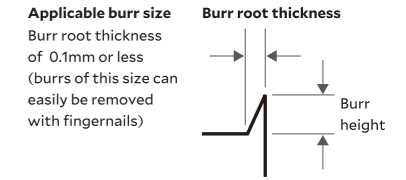

Tool composition

Brush and Shank are sold separately. Assemble Brush and Shank before use.



Applicable equipment

This tool can be mounted on equipment which can control the rotational speed. The tool must be rotated over 4000 min⁻¹.

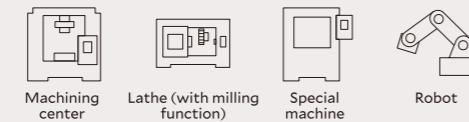

Tool composition

Brush, Collar, and Shank are sold separately.

Applicable equipment

This tool can be mounted on full cover type of equipment which can control the rotational speed. The tool must be rotated over 6,500 min⁻¹.

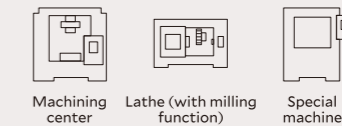

Brush

Brush (Color)	Product code	Brush diameter (mm)	Bristle length (mm)	Depth of shank inserted (mm)	Maximum rotational speed (min ⁻¹)	Target hole diameter (mm)	Matching shank	Fig
A33 (Dark Blue)	CH-A34-15	ϕ 15	60	10	9000	$\phi 20 - 25$	CH-SH-6	7
	CH-A34-20	ϕ 20	60	16	9000	$\phi 25 - 30$	CH-SH-8	7
	CH-A34-25	ϕ 25	60	16	9000	$\phi 30 - 35$	CH-SH-8	7

*The Brush size is approximate as the tip expands by rotating.
*Overall length of the Brush with the shank attached is 150 mm.

Shank

Product code	Shaft diameter Ds (mm)	Shank length ℓ_s (mm)	Applicable Brush	Fig
CH-SH-6	ϕ 6	80	CH-A34-15	8
CH-SH-8	ϕ 8	86	CH-A34-20, CH-A34-25	8

Precautions for Use

The clamp length must be 30mm or more when attaching this tool on the machine, and make sure it is affixed rigidly.

The Brush will break off if:

- machined beyond the maximum rotational speed
- used with a pneumatic tool
- rotated outside the cylinder (outside workpiece)
- the distance from the hole entrance to the target is 20 mm or less

The Brush may break off when:

- the crosshole diameter larger than $\phi 12$
- *When using this product on a crosshole diameter larger than $\phi 12$, please contact us.

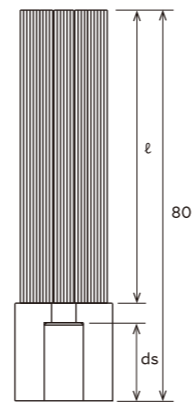

Fig7

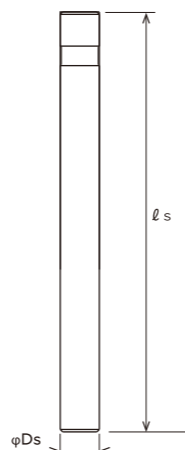

Fig8



Instruction manual

See P.12 for "How to use"

Brush (Color)	Product code	Brush diameter (mm)	Shank diameter Ds (mm)	Overall length L (mm)	Maximum rotational speed (min ⁻¹)
A12 (Red)	*	ϕ 3	ϕ 4	400	12000
	*	ϕ 5	ϕ 6	400	12000
	*	ϕ 7	ϕ 8	400	12000
	*	ϕ 11	ϕ 12	400	12000
A33 (Blue)	*	ϕ 3	ϕ 4	410	12000
	*	ϕ 5	ϕ 6	410	12000
	*	ϕ 7	ϕ 8	410	12000
	*	ϕ 11	ϕ 12	410	12000

*Please contact us for the details as it is a special order item.
*The Brush size is approximate as the tip expands by rotating.

Precautions for Use

- The Brush will break off if:
- rotated beyond the maximum rotational speed
 - used with a pneumatic tool
 - rotated outside the cylinder (outside workpiece)

- In the following cases, the Brush may break off:
- off-center cross hole and angled cross hole
 - if the cross hole diameter is equal to or greater than the main bore diameter in case of T-shaped cross hole
 - if the cross hole diameter is more than 70% of the main bore diameter in case of cross-shaped

Machining Parameters

Standard Machining Parameters

Rotational speed: 7000 min⁻¹ Feed rate: 300 mm/min

Adjusting the rotational speed

Optimize the performance of this Brush by adjusting the rotational speed depending on the Brush size, main bore diameter, and the Brush wear amount by referring to charts below. When the Brush is new, refer to the continuous line (—). When the Brush is worn by 10mm, refer to the dotted line (---). When the Brush is worn by 20mm, refer to the dotted line (.....).

CH-A34-15
Target hole diameter: $\phi 20 - 25$ mm

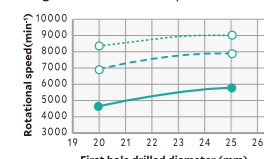

CH-A34-20
Target hole diameter: $\phi 25 - 30$ mm

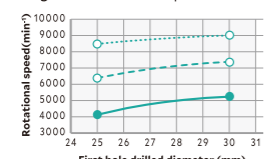

CH-A34-25
Target hole diameter: $\phi 30 - 35$ mm

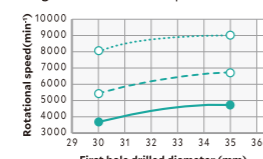

Rotational direction

A uniform deburring and edge quality can be achieved by rotating the tool in both clockwise and counter-clockwise directions.

Applicable material

The Brush can be used for any materials such as plastics, nonferrous materials, steel and stainless steel.



Instruction manual

See P.12 for machining conditions

See P.42 to select Brush color

XEBEC Brush™ Wheel Type Patented

Ideal for deburring and polishing inner diameters, side walls, and thread outside diameters

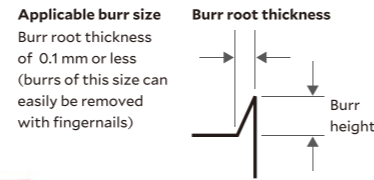

Video (YouTube)

Tool composition

Brush and Shank are sold separately. Assemble Brush and Shank before use.

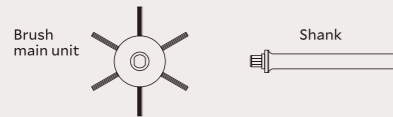

Applicable equipment

This tool can be mounted on equipment shown below:

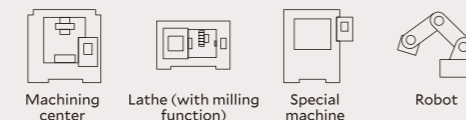

Brush main unit

Brush (Color)	Product code	Brush diameter (mm)	Number of bundles	Matching shank	Fig
A11 (Red)	W-A11-50	φ 50	6	W-SH-M/L	9
	W-A11-75	φ 75	6		

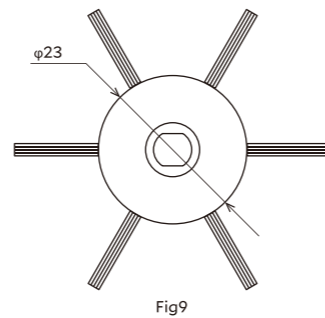

Shank

Product code	Shank diameter D _s (mm)	Shank length ℓ _s (mm)	Fig
W-SH-M	φ 8	70	10
W-SH-L	φ 12	150	10

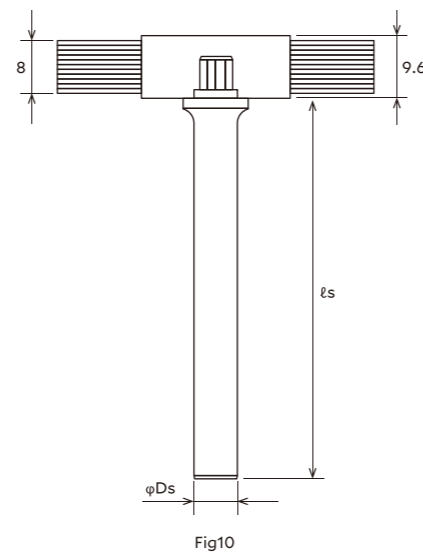

Applications

Deburring automation

Thread Outside Diameter



Material : SCM
Previous process : Turning
Tool : W-A11-50

Before

Deburring was done by filing but failed to remove all burrs. Quality was not stabilized.

After

All burrs are removed with the quality stabilized.

Deburring automation

Side Wall

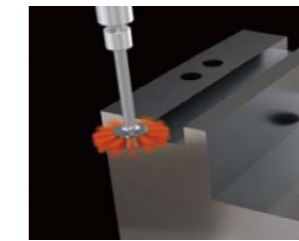

Material : S50C
Previous process : End milling
Tool : W-A11-50

Before

Had a difficulty removing burrs formed on the side edge. Burrs were removed by manual work.

After

Burrs are removed in the machine. Manual work is eliminated.

How to use

As shown in Figure 1, the best approach to remove burrs formed on Surface A is to place a center of a Brush at the center angle to the edge.

In such a case, rotate the Brush in both clockwise and counter-clockwise directions.

If it is difficult to place the Brush as shown in Figure 1, it is also possible to place the Brush as shown in Figure 2. Also in such a case, rotate the Brush in both clockwise and counter-clockwise directions.

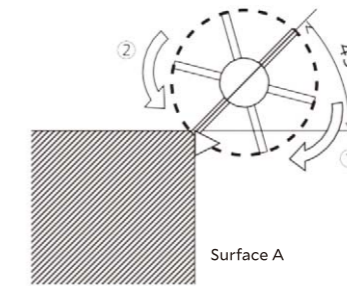

Figure 1

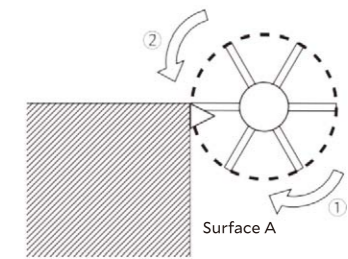

Figure 2

Machining Parameters

Standard Machining Parameters

Product code	Cutting speed (m/min)	Rotational speed (min ⁻¹)	Feed per bundle (mm/bundle)	Depth of cut (mm)	Feed (mm/min)
W-A11-50	250	1600	0.5	0.2	4800
W-A11-75	250	1000	0.5	0.2	3000

Maximums for machining conditions

Product code	Cutting speed (m/min)	Rotational speed (min ⁻¹)	Depth of cut (mm)	Feed (mm/min)
W-A11-50, W-A11-75	150 - 350	≤1.5	≤0.5	3000

*As bristles are worn out, bristle length becomes shorter and increases stiffness, causing bristles to be broken. If bristles breakage occurs, decrease the depth of cut.



Instruction manual

XEBEC Optional Tools

XEBEC Optional Tools

Make it easier to adjust the Brush projection length, thereby achieving more consistent deburring and polishing.



With a Brush



XEBEC Floating Holder™

The built-in spring helps to maintain stable load, contributing to consistent edge quality and reduction of the frequency to adjust the depth of cut.

Product in Use



[Video \(YouTube\)](#)



With a Brush



XEBEC Self-Adjusting Sleeve™

Automatically adjusts the Brush projection length with the built-in gear mechanism. Helps prevent human errors and achieve consistent machining performance.

Product in Use



[Video \(YouTube\)](#)



XEBEC Brush Length Adjustment Tool™

Tool for quick in-machine brush length adjustment.

XEBEC Floating Holder™ Patented

Straight Shank Type
BT Shank Type

The built-in spring helps to maintain stable load, which enables consistent performance, while reducing the need to adjust the Brush projection length frequently.

Straight Shank Type compatible with
XEBEC Brush Surface (φ6 – 100)

BT Shank Type compatible with
XEBEC Brush Surface (φ6 – 25)



Video (YouTube)

Applicable equipment [Straight Shank Type]

This tool can be mounted on equipment shown below:

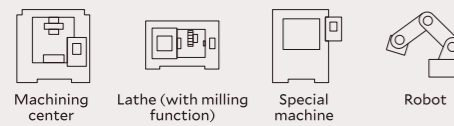

Applicable equipment [BT Shank Type]

This tool can be used with machine tools that are compatible with BT30/40 shanks.

Straight Shank Type

Product code	Target brush diameter (mm)	Diameter for the sleeve shank (mm)	Maximum rotational speed (min ⁻¹)	Accessories	Fig
FH-ST12-SL10	φ 6	φ 6 (with the supplied bush 1)	10000	1. φ 6 bush 2. φ 8 bush 3. Low-pressure spring 4. Standard spring* 5. High-pressure spring * Installed when shipped	11
	φ 15	φ 6 (with the supplied bush 2)	6000		
	φ 25	φ 8 (with the supplied bush 3)	5000		
FH-ST20-60	φ 40	φ 10	3000	φ 12 bush	12
FH-ST20-100	φ 60	φ 12	2000	φ 16 bush	12

*Please refer to P. 20 for the spring load.
*Optional φ3 bush is available.

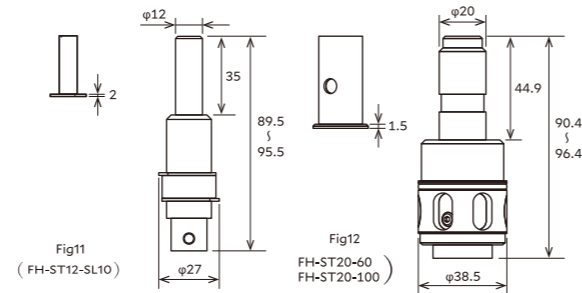

BT Shank Type

Product code	Target brush diameter (mm)	Diameter for the sleeve shank (mm)	Maximum rotational speed (min ⁻¹)	Length under gauge line (mm)	Fig
FH-BT30	φ 6	φ 6 (with φ 6 bush)	10000	75	13
	φ 15	φ 6 (with φ 6 bush)	6000		
	φ 25	φ 8	5000		
FH-BT40	φ 6	φ 6 (with φ 6 bush)	10000	60	14
	φ 15	φ 6 (with φ 6 bush)	6000		
	φ 25	φ 8	5000		

*φ6 bush is available separately.
*Please refer to P. 20 for the spring load.

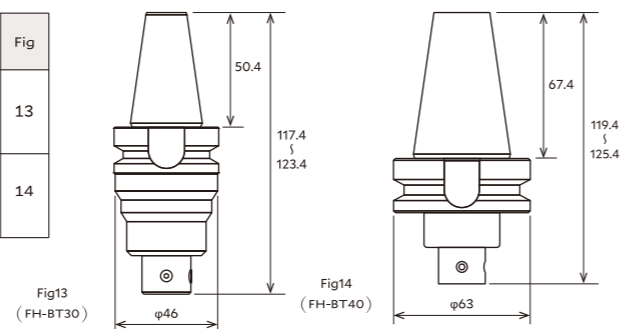

Precautions for Use

- Approach the tool vertically when making it engaged with workpiece.
- It can not be used if there are intermittent machining or protrusions.
- Using on horizontal machining center, it may not function when spring load is low.

Mechanism

This tool has a built-in spring. Compress the spring after the Brush comes in contact with the workpiece surface.

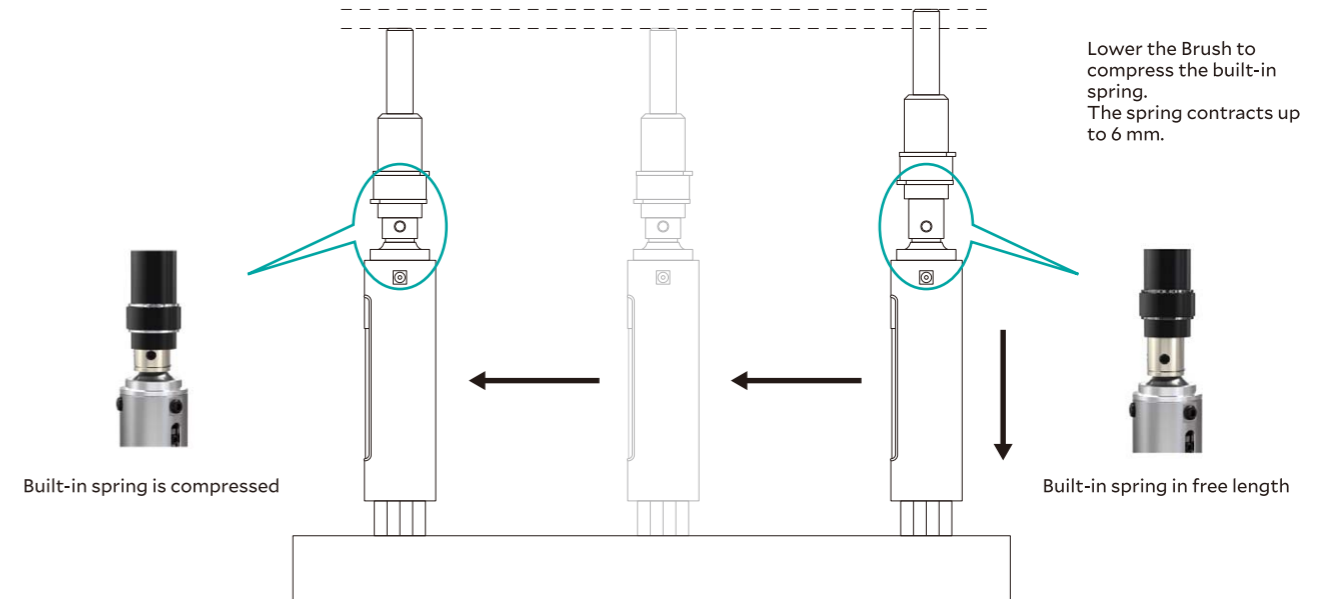

How to use

Product in Use

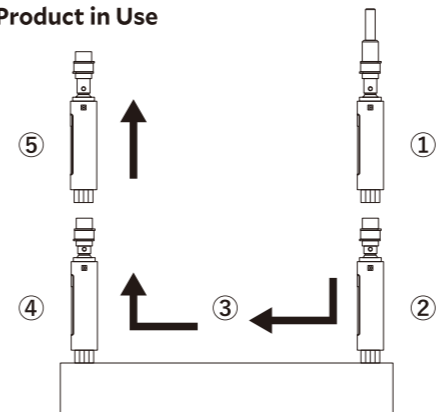

The following describes effective use of the tool.

- Approach the workpiece surface from above without rotating the Brush.
- Set the depth of cut and compress the spring.
- Rotate the Brush and start feeding with the spring compressed.
- Stop rotation and feed.
- Remove the Brush upward from the workpiece surface.

Non-applicable workpiece conditions

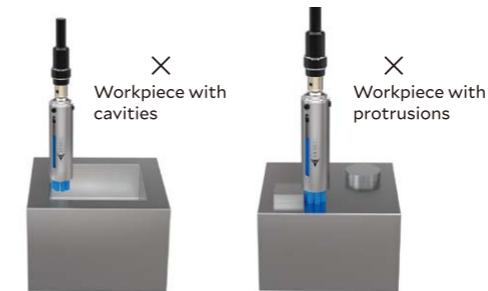

Avoid cavities and protrusions to ensure the floating function works properly.

FH-ST12-SL10

Spring type	Outer diameter (mm)	Spring constant (N/mm)	Overall length (mm)	Load by stroke (N)	
				0mm	6mm
Standard spring (Installed)	φ10	0.3	40	4.5	6.3
Low-pressure spring (Attachment)	φ10	0.3	30	1.5	3.3
High-pressure spring (Attachment)	φ10	0.55	39	7.2	10.5
Maximum load spring (Sold separately)	φ10	3.03	30	15.2	33.4

FH-ST20-60/100 FH-BT30/40

Load adjustment	Load by stroke (N)		Adjustment Screw Position
	0mm	6mm	
Standard Float	2	6	When load adjustment screw 2 is at the end of the shaft.
Higher Float	6	10	When load adjustment screw 2 is at the back of the shaft.



Instruction manual

XEBEC Self-Adjusting Sleeve™ Patented

Compatible with
XEBEC Brush Surface (φ6 - 40)

Automatically adjusts the Brush protrusion length with the built-in gear mechanism.
Helps prevent human errors and achieve consistent machining performance.



Video (YouTube)

Tool composition

This tool consists of Sleeve and Rack gear.
Brush is available separately.

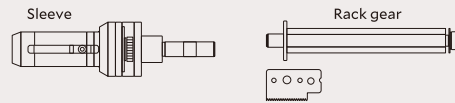

Applicable equipment

This tool can be used with a machine capable of precise control of the angular position of the Sleeve.

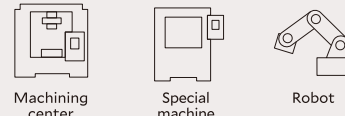

Product code	Target brush (Product code)	Sleeve outer diameter Dc (mm)	Outermost diameter Dc (mm)	Shank diameter Ds (mm)	Overall length L (mm)	Shank length ℓs (mm)	Main body weight (g)	Maximum rotational speed (min-1)	Fig
XP-AUT06M	A13-CB06M	φ 14.2	φ 37	φ 10	124.1	35	220	10000	15
	A11-CB06M								
	A21-CB06M								
	A32-CB06M								
XP-AUT15M	A13-CB15M	φ 23.4	φ 37	φ 10	136.3	35	270	6000	15
	A11-CB15M								
	A21-CB15M								
	A32-CB15M								
XP-AUT25M	A11-CB25M	φ 34.6	φ 60	φ 16	189	41.5	795	5000	15
	A21-CB25M								
	A32-CB25M								
XP-AUT40M	A11-CB40M	φ 50	φ 60	φ 16	189	41.5	910	3000	15
	A21-CB40M								
	A32-CB40M								

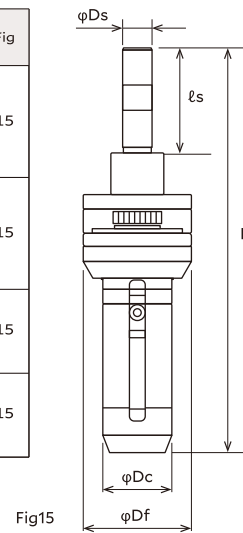
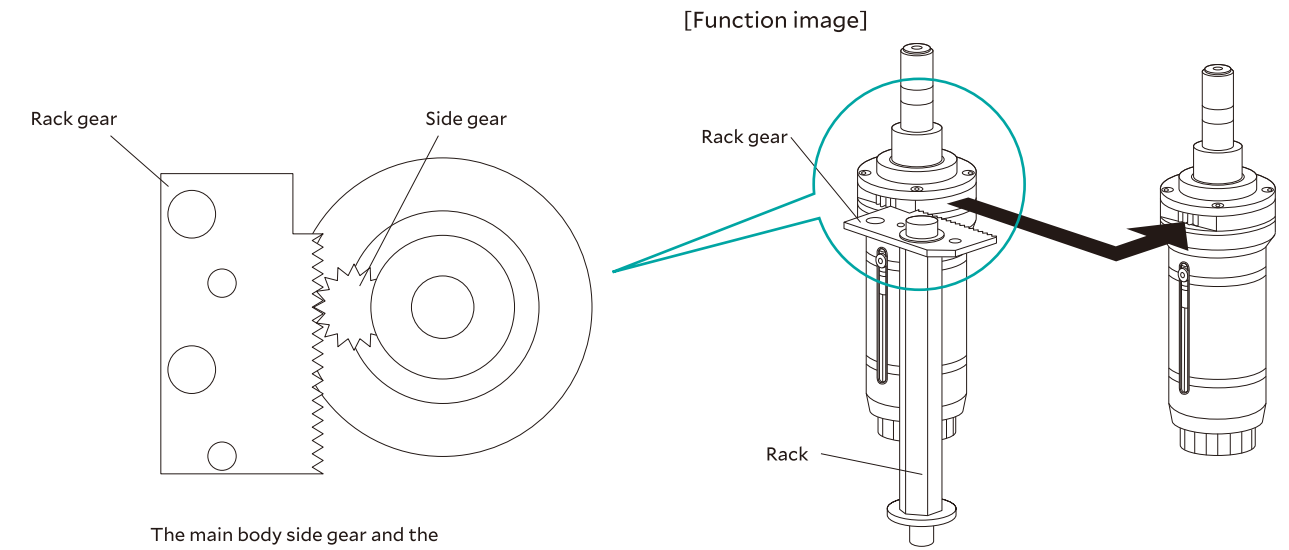

Fig15

How to Use

Mount the Rack Gear inside the machine.

The Brush projection length is adjusted by rotating the Side gear built inside the Sleeve with the Rack gear.



The main body side gear and the rack gear are meshed.

As shown in the figure above, the main body passes through the rack.

Brush projection length

It is possible to adjust the Brush projection length in increments of 0.05mm. In one single pass, it is possible to make an adjustment of up to 1mm.

This allows adjustments be made at a predetermined interval corresponding to the tool wear.



Instruction manual

XEBEC Short BT Holder™

Compact tool holder whose length under the gauge line is 23.5mm (including bush flange thickness 1.5mm).
Optimal when available space is limited.

Compatible with
XEBEC Brush Surface
XEBEC Self-Adjusting Sleeve
XEBEC Floating Holder



Product code	Target shank diameter (mm)
SH-BT30	φ20

*For use with XEBEC tools only

Please visit our website, YouTube channel and LinkedIn for detailed information.

Website



YouTube / XEBEC TECHNOLOGY English



LinkedIn



Tool outline

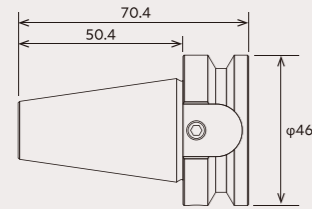

Applicable equipment

This tool can be used with machine tools that are compatible with BT30 shanks.

XEBEC Brush Length Adjustment Tool™

Tool to adjust Brush projection length easily.

Compatible with
XEBEC Brush Surface (φ15 - 100)

Product code	Corresponding Brush diameter (mm)	Size of built-in hexagonal wrench (mm)
XP-EZ-001	φ15 / φ25 / φ40 / φ60 / φ100	1.5, 2.0

How to use

1. Move the brush rest using adjustment knob to set the amount of brush projection.
2. Tighten the fixing nut.
3. Hold the unit in one hand, and align the sleeve rest with sleeve tip.
4. Loosen the screws to allow the brush to drop to the brush rest.
5. Tighten the screws to secure the brush in place.

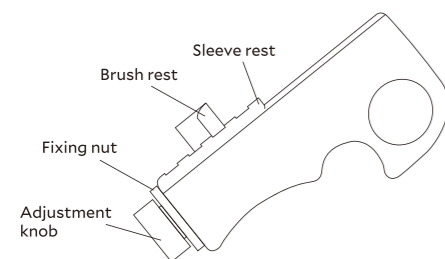

Spherical deburring cutter and custom-made tool path

XEBEC Back Burr Cutter and Path™

“There must be a way to automate cross hole deburring”

We embarked on the challenge to find the solution to a problem that remained unsolved as we promoted automation of deburring. The goal was to deburr complex shaped edges without scratching adjacent surfaces. Our solution combines technologies from two different fields; optimal tool geometry ideal for deburring, and generation of ideal tool paths that inhibit secondary burrs. This product symbolizes our approach of focusing on solving a problem, without any emphasis on what categories of technology to use.



Website link

An innovative CNC crosshole deburring solution, which, in combination with the spherical deburring cutter and the custom-made Path (NC tool path), enables high-speed, high-precision deburring of complex 3D-curved edges, while maximizing tool life. The Path can be used right away after adding it to the NC program, greatly saving your time from having to create the optimal toolpath.

XEBEC Back Burr Cutter

Made of micro-grain cemented carbide and coated with AlTiCrN, the highly durable and heat-resistant tool features a blade design specially optimized for deburring that maximizes cutting performance, while inhibiting formation of secondary burrs. Capable of deburring workpieces made of a wide range of materials, from non-ferrous metals such as aluminum alloys to difficult-to-cut metals such as titanium.



XEBEC Path

Custom-made NC tool path

```

01_0.20_EdgeBreakAmount - Notepad
File Edit Format View Help
(K INNER-1D31, -2018, -T5.8-AR-90, -EO)
(EDGE BREAK AMOUNT 0.20)
(UPPER EDGE)
(INC)
(DOWN CUT)

X0.000Y0.000Z0.000
X0.000Y0.000Z-7.085
X-0.000Y-6.468Z0.000
X0.792Y0.042Z0.030
X0.776Y0.124Z0.088
X0.748Y0.202Z0.139
X0.709Y0.274Z0.179
    
```

High quality

Optimized tool path and ideal approach angle achieve uniform edge break lengths, while inhibiting formation of secondary burrs.

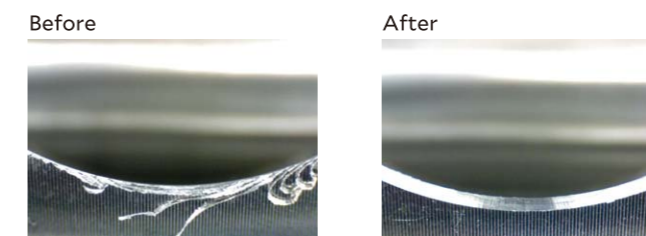

XEBEC Path includes a set of five toolpaths corresponding to five different edge break lengths. Refer to P. 29.

Long tool life

The continuous displacement of the contact point of the cutter during machining increases the tool life many times over compared to comparable tool solutions.

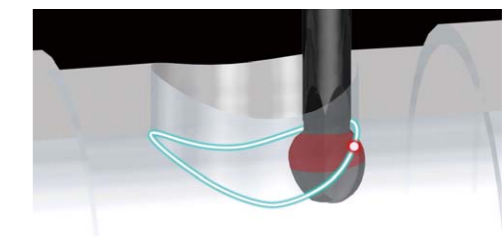

● Range of contact point

Super high-speed machining

Directly approaches the edges that need to be deburred, thereby minimizing the cycle time (up to 10 times faster than conventional tools)

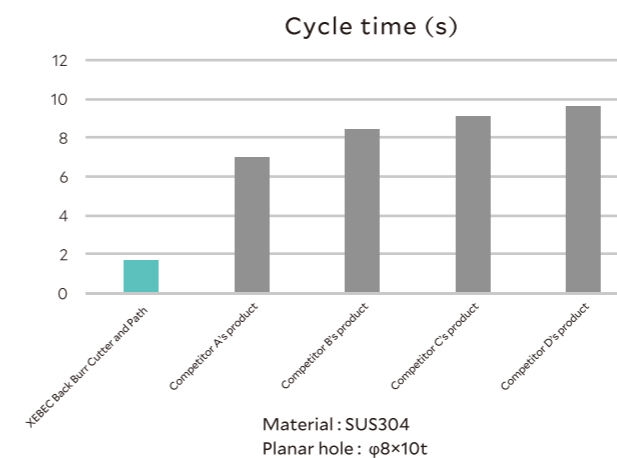

XEBEC Back Burr Cutter™

Perfect for deburring both front and back of a drilled hole.

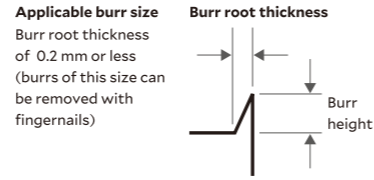

Tool composition

Spherical deburring cutter and custom-made tool Path. For information of custom-made Path machining program, please refer to P.29 - 30.

Applicable equipment

This tool can be used on equipment with 3-axis simultaneous control.

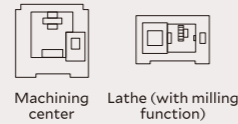

AlTiCrN coated

	Steel	Stainless steel	Cast iron	Heat resistant alloy	Nonferrous metals				
	Product code	Cutter diameter Dc (mm)	Cutter radius R (mm)	Neck diameter dn (mm)	Neck Length L2 (mm)	Overall length L1 (mm)	Shank diameter Ds (mm)	Number of blades	Fig
3 blades short type	XC-08-AS-3F	φ0.8	0.4	φ0.48	3	60	φ 3	3	16
	XC-13-AS-3F	φ1.3	0.65	φ0.78	5	60	φ 3	3	16
	XC-18-AS-3F	φ1.8	0.9	φ1.1	6	60	φ 3	3	16
	XC-23-AS-3F	φ2.3	1.15	φ1.4	7.5	70	φ 3	3	16
	XC-28-AS-3F	φ2.8	1.4	φ1.7	9	70	φ 4	3	16
	XC-33-AS-3F	φ3.3	1.65	φ2.0	10.5	70	φ 4	3	16
	XC-38-AS-3F	φ3.8	1.9	φ2.4	12	70	φ 4	3	16
	XC-48-AS-3F	φ4.8	2.4	φ3.0	15	70	φ 6	3	16
	XC-58-AS-3F	φ5.8	2.9	φ3.5	18	70	φ 6	3	16
	XC-78-AS-3F	φ7.8	3.9	φ4.7	24	100	φ 8	3	16
	XC-98-AS-3F	φ9.8	4.9	φ5.9	30	120	φ10	3	16
	Regular type	XC-08-A	φ0.8	0.4	φ0.48	5	60	φ 3	2
XC-13-A		φ1.3	0.65	φ0.78	8	60	φ 3	2	16
XC-18-A		φ1.8	0.9	φ1.1	10	60	φ 3	2	16
XC-23-A		φ2.3	1.15	φ1.4	12.5	70	φ 3	2	16
XC-28-A		φ2.8	1.4	φ1.7	15	70	φ 4	2	16
XC-33-A		φ3.3	1.65	φ2.0	17.5	70	φ 4	2	16
XC-38-A		φ3.8	1.9	φ2.4	20	70	φ 4	2	16
XC-48-A		φ4.8	2.4	φ3.0	25	70	φ 6	2	16
XC-58-A		φ5.8	2.9	φ3.5	30	70	φ 6	2	16
XC-78-A		φ7.8	3.9	φ4.7	40	100	φ 8	3	16
Straight type	XC-18-B	φ1.8	0.9	φ1.1	—	50	φ1.1	2	17
	XC-23-B	φ2.3	1.15	φ1.4	—	60	φ1.4	2	17
	XC-28-B	φ2.8	1.4	φ1.7	—	70	φ1.7	2	17
	XC-33-B	φ3.3	1.65	φ2.0	—	80	φ2.0	2	17
	XC-38-B	φ3.8	1.9	φ2.4	—	85	φ2.4	2	17
	XC-48-B	φ4.8	2.4	φ3.0	—	105	φ3.0	2	17
	XC-58-B	φ5.8	2.9	φ3.5	—	120	φ3.5	2	17
	XC-78-B	φ7.8	3.9	φ4.7	—	150	φ4.7	3	17
	XC-98-B	φ9.8	4.9	φ5.9	—	180	φ5.9	3	17

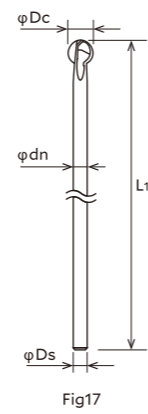
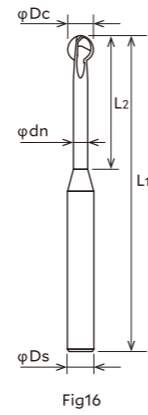

Uncoated

	Nonferrous metals	Resin							
	Product code	Cutter diameter Dc (mm)	Cutter radius R (mm)	Neck diameter dn (mm)	Neck Length L2 (mm)	Overall length L1 (mm)	Shank diameter Ds (mm)	Number of blades	Fig
Regular type	XC-08-A-N	φ0.8	0.4	φ0.48	5	60	φ 3	2	16
	XC-13-A-N	φ1.3	0.65	φ0.78	8	60	φ 3	2	16
	XC-18-A-N	φ1.8	0.9	φ1.1	10	60	φ 3	2	16
	XC-23-A-N	φ2.3	1.15	φ1.4	12.5	70	φ 3	2	16
	XC-28-A-N	φ2.8	1.4	φ1.7	15	70	φ 4	2	16
	XC-33-A-N	φ3.3	1.65	φ2.0	17.5	70	φ 4	2	16
	XC-38-A-N	φ3.8	1.9	φ2.4	20	70	φ 4	2	16
	XC-48-A-N	φ4.8	2.4	φ3.0	25	70	φ 6	2	16
	XC-58-A-N	φ5.8	2.9	φ3.5	30	70	φ 6	2	16
	XC-78-A-N	φ7.8	3.9	φ4.7	40	100	φ 8	3	16
	XC-98-A-N	φ9.8	4.9	φ5.9	50	120	φ10	3	16

Precautions for Use

- XEBEC Back Burr Cutter is designed for NC machines. Never use it as a hand tool.

Caution

- Turn on advanced preview control of the machine tool helps to reduce errors in contouring the edges to be deburred.
- The processing error of the hole position must be kept as small as possible.

Applications

CNC deburring of valve

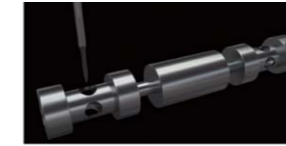

Material : Free-cutting steel
Previous process : Drilling
Tool : XC-18-A

Before

Deburring was done with φ2 chamfering, nylon brush and φ3 chamfering. 3-step deburring with a different tool for each step, with a long cycle time.

After

Deburring is done with a single Cutter. Shortened the deburring time by 9 secs. per workpiece. Reduced the tool costs by reducing the number of tools.

CNC deburring of industrial component

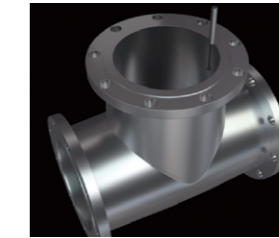

Material : SUS304
Previous process : Tapping
Tool : XC-18-A

Before

Deburring by manual work, tapping and air blowing. There were two more processes necessary after time-consuming deburring. A long cycle time was a problem.

After

XEBEC Path for tap holes was introduced. Deburring time is shortened from 120 sec. to 40 sec. Manual work is no longer needed. Improved safety.

Machining Parameters

Standard Machining Parameters

AlTiCrN coated

	Product code	Cutter diameter φDc (mm)	Tool Projection Length (mm)	Number of blades	Steel, stainless steel, cast iron, heat resistant alloy		Nonferrous metals	
					Rotational speed n (min ⁻¹)	Feed rate Vf (mm/min)	Rotational speed n (min ⁻¹)	Feed rate Vf (mm/min)
3 blades short type	XC-08-AS-3F	φ0.8	3Dc	3	20000	1080	20000	1170
	XC-13-AS-3F	φ1.3	3Dc	3	20000	1080	20000	1170
	XC-18-AS-3F	φ1.8	3Dc	3	20000	1080	20000	1170
	XC-23-AS-3F	φ2.3	3Dc	3	15000	1350	18000	1710
	XC-28-AS-3F	φ2.8	3Dc	3	12500	1800	15000	2520
	XC-33-AS-3F	φ3.3	3Dc	3	10600	1890	12700	2250
	XC-38-AS-3F	φ3.8	3Dc	3	9200	2160	11000	2880
	XC-48-AS-3F	φ4.8	3Dc	3	7200	1980	8500	2880
	XC-58-AS-3F	φ5.8	3Dc	3	6000	1620	7000	2160
	XC-78-AS-3F	φ7.8	3Dc	3	4500	1620	5400	1920
	XC-98-AS-3F	φ9.8	3Dc	3	3600	1320	4300	1560
	Regular type	XC-08-A	φ0.8	5Dc	2	20000	600	20000
XC-13-A		φ1.3	5Dc	2	20000	600	20000	650
XC-18-A		φ1.8	5Dc	2	20000	600	20000	650
XC-23-A		φ2.3	5Dc	2	15000	750	18000	950
XC-28-A		φ2.8	5Dc	2	12500	1000	15000	1400
XC-33-A		φ3.3	5Dc	2	10600	1050	12700	1250
XC-38-A		φ3.8	5Dc	2	9200	1200	11000	1600
XC-48-A		φ4.8	5Dc	2	7200	1100	8500	1600
XC-58-A		φ5.8	5Dc	2	6000	900	7000	1200
XC-78-A		φ7.8	5Dc	3	4500	1350	5400	1600
Straight type	XC-18-B	φ1.8	10Dc	2	4400	220	4400	220
	XC-23-B	φ2.3	10Dc	2	3500	220	3500	220
	XC-28-B	φ2.8	10Dc	2	2800	220	2800	220
	XC-33-B	φ3.3	10Dc	2	2400	190	2400	190
	XC-38-B	φ3.8	10Dc	2	2000	160	2000	160
	XC-48-B	φ4.8	10Dc	2	1600	120	1600	120
	XC-58-B	φ5.8	10Dc	2	1300	100	1300	100
	XC-78-B	φ7.8	10Dc	3	650	70	650	70
	XC-98-B	φ9.8	10Dc	3	500	50	500	50

Uncoated

	Nonferrous metals	Resin				
	Product code	Cutter diameter φDc (mm)	Projection amount (mm)	Number of blades	Rotational speed n (min ⁻¹)	Feed rate Vf (mm/min)
Regular type	XC-08-A-N	φ0.8	5Dc	2	20000	650
	XC-13-A-N	φ1.3	5Dc	2	20000	650
	XC-18-A-N	φ1.8	5Dc	2	20000	650
	XC-23-A-N	φ2.3	5Dc	2	18000	950
	XC-28-A-N	φ2.8	5Dc	2	15000	1400
	XC-33-A-N	φ3.3	5Dc	2	12700	1250
	XC-38-A-N	φ3.8	5Dc	2	11000	1600
	XC-48-A-N	φ4.8	5Dc	2	8500	1600
	XC-58-A-N	φ5.8	5Dc	2	7000	1200
	XC-78-A-N	φ7.8	5Dc	3	5400	1600
	XC-98-A-N	φ9.8	5Dc	3	4300	1300

- * Tool projection length is defined by multiples of Dc (Cutter Diameter)
- * For the Straight type, the tool projection length may be varied, and optimal machining parameters for specified tool projection lengths can be found in the instruction manual
- * Rotational speed and feed rates listed are to be referred to as a guide for initial machining. Adjust them as needed.
- * In case vibration or abnormal noise is detected, lower the rotational speed and feed rate by the same rate.
- * If the max rotational speed or feed rate of the machine is below the parameters listed above, lower them both at the same rate to be within the machine's capability.



Instruction manual

An integral component of this deburring solution, XEBEC Path is a custom-made NC tool path that ensures optimal performance of XEBEC Back Burr Cutter

```

01_020_EdgeBreakAmount - Notepad
File Edit Format View Help
((INNER-1D31.-2018.-T5.8-AR-90.-E0)
(EDGE BREAK AMOUNT 0.20)
(UPPER EDGE)
(INC)
(DOWN CUT)

X0.000Y0.000Z0.000
X0.000Y0.000Z-7.085
X-0.000Y-6.468Z0.000
X0.792Y0.042Z0.030
X0.776Y0.124Z0.088
X0.748Y0.202Z0.139
X0.708Y0.274Z0.179
    
```

Standard Path

For predetermined set of commonly encountered cross hole configurations shown below, standardized Paths are readily available.

Quotation will be submitted soon after you apply for a Standard Path via the Online Application Form detailed on Page 30.

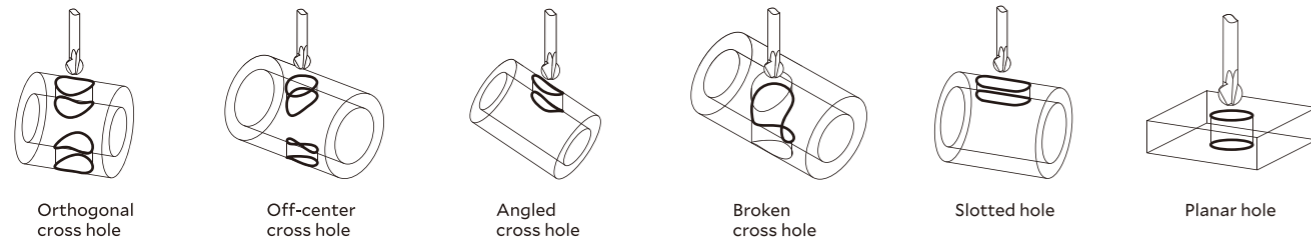

Deburring amount and allowable cumulative error

Product code	Cutter diameter Dc (mm)	Edge Break Length (mm)					Max Allowed Accumulated Variance (mm)
		①	②	③	④	⑤	
XC-08-AS-3F/A/A-N	φ 0.8	0.02	0.04	0.06	0.08	0.10	0.03
XC-13-AS-3F/A/A-N	φ 1.3	0.04	0.06	0.08	0.10	0.12	0.05
XC-18-AS-3F/A/B/A-N	φ 1.8	0.07	0.09	0.11	0.13	0.15	0.08
XC-23-AS-3F/A/B/A-N	φ 2.3	0.07	0.09	0.11	0.13	0.15	0.09
XC-28-AS-3F/A/B/A-N	φ 2.8	0.08	0.11	0.14	0.17	0.20	0.10
XC-33-AS-3F/A/B/A-N	φ 3.3	0.08	0.11	0.14	0.17	0.20	0.11
XC-38-AS-3F/A/B/A-N	φ 3.8	0.09	0.13	0.17	0.21	0.25	0.12
XC-48-AS-3F/A/B/A-N	φ 4.8	0.10	0.15	0.20	0.25	0.30	0.15
XC-58-AS-3F/A/B/A-N	φ 5.8	0.10	0.15	0.20	0.25	0.30	0.18
XC-78-AS-3F/A/B/A-N	φ 7.8	0.10	0.15	0.20	0.25	0.30	0.18
XC-98-AS-3F/A/B/A-N	φ 9.8	0.10	0.15	0.20	0.25	0.30	0.18

Deburring amount means "a width of an edge after deburring".

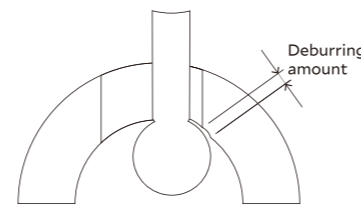

Standard Path for Tapped Holes

Standardized Paths are readily available for metric thread sizes ranging between M3 and M24.

Tap size	Applicable Cutter Product code	Cutter diameter Dc (mm)	Deburring amount (mm)
M3	XC-23-AS-3F/A/B/A-N	φ 2.3	0.11
M4	XC-28-AS-3F/A/B/A-N	φ 2.8	0.14
M5	XC-33-AS-3F/A/B/A-N	φ 3.3	0.14
M6	XC-38-AS-3F/A/B/A-N	φ 3.8	0.17
M8	XC-48-AS-3F/A/B/A-N	φ 4.8	0.20
M10	XC-58-AS-3F/A/B/A-N	φ 5.8	0.20
M12	XC-78-AS-3F/A/B/A-N	φ 7.8	0.20
M16 - 24	XC-98-AS-3F/A/B/A-N	φ 9.8	0.20

XEBEC Path All Edges

Tool Path customized for extremely complex edge profiles.

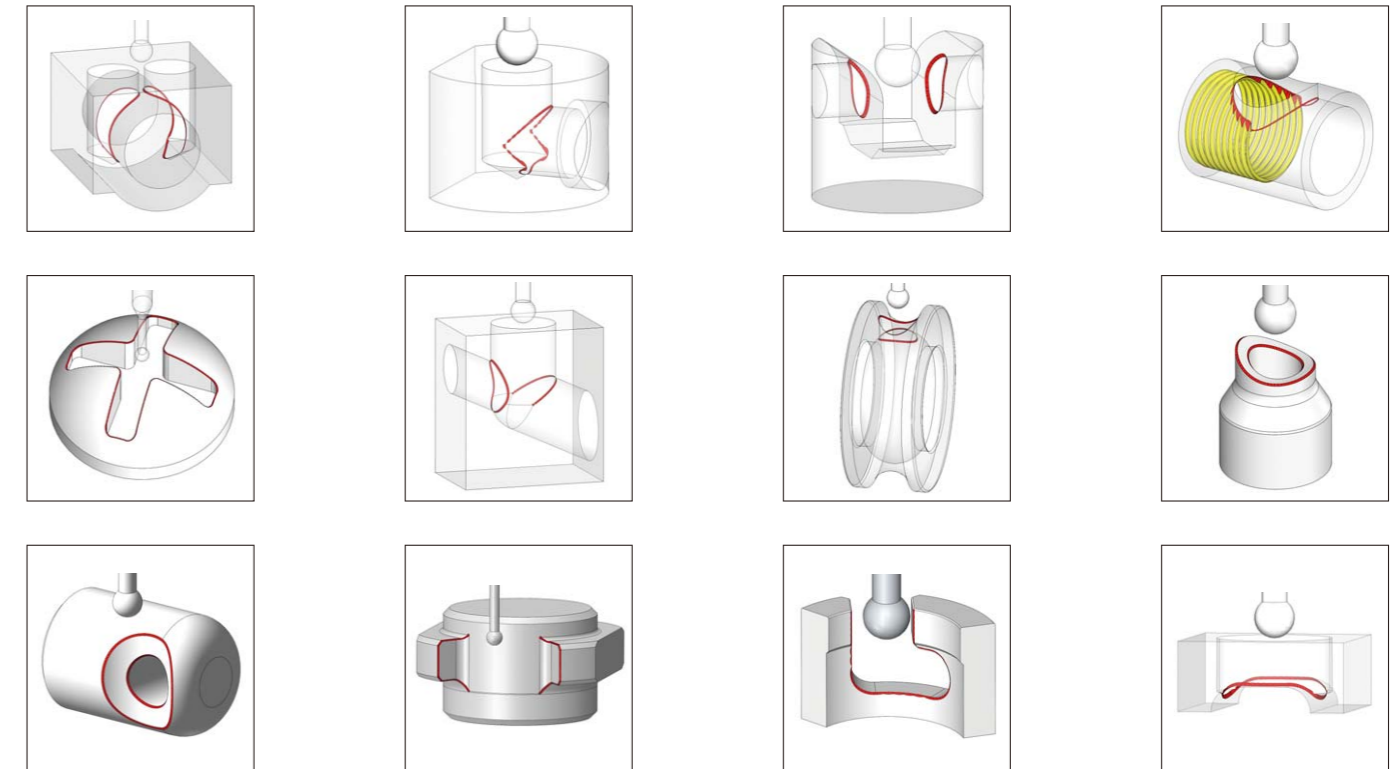

How to Order

Standard Path

STEP 1
Free assessment

You can check whether XEBEC Back Burr Cutter and Path can be implemented on your workpiece and machining equipment. The result is immediately available.

STEP 2
Quotation

You can receive a quotation by submitting your contact information.

STEP 3
Order

Send your order to our distributor in your region after confirming the details.

***Online Application Form**

Visit the Online Application Form for assessment and to submit a request for quotation. All you need to do is to enter a few dimensions including hole diameters and to specify the orientation of the workpiece inside the machine.



Website link

***To request XEBEC Path All Edges, please contact us.**

XEBEC Ceramic Stone™

XEBEC Ceramic Stone™

“His dream will come true”

The founder of XEBEC Technology founded the company, recognizing the immense potential of an invention by a childhood friend, the ceramic stone that does not break, crack, or chip, which can be formed into various shapes. Aiming to make it the best in the world, the company endeavored to develop ceramic fibers ideal for polishing in joint effort with a material manufacturer. The ceramic stone became our first patented product with an original structure that maximizes strength and polishing performance. XEBEC Ceramic Stone dominates the market share for polishing ribs and bosses of metal molds and other surfaces with small gaps and openings, making manual deburring safe and efficient.



Website link

XEBEC Stone™ Flexible Shaft Patented

Ideal for deburring and polishing front and back of cross holes, grooves and areas that are deep inside the workpiece. The spring steel flexible shaft absorbs vibrations which makes soft contact with the surface possible.

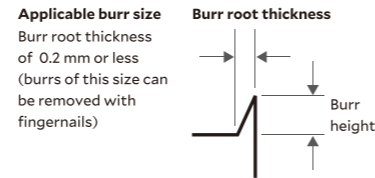

Applicable equipment

This tool can be mounted on equipment which can control the rotational speed.

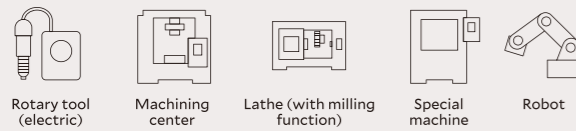

Ball type

Equivalent grit (Color)	Product code	Head size (mm)	Shaft diameter (mm)	Shank diameter (mm)	Overall length L (mm)	Standard rotational speed (min ⁻¹)	Maximum rotational speed (min ⁻¹)	Fig
#800 (Blue)	CH-PB-3B	φ 3	φ 1.5	φ 3	70	5000 - 8000	15000	18
	CH-PB-4B	φ 4	φ 1.5	φ 3	70	5000 - 8000	13000	18
	CH-PB-5B	φ 5	φ 1.5	φ 3	70	5000 - 8000	12000	18
	CH-PB-6B	φ 6	φ 1.5	φ 3	70	5000 - 8000	10000	18
#400 (Orange)	CH-PO-3B	φ 3	φ 1.5	φ 3	70	5000 - 8000	15000	18
	CH-PO-4B	φ 4	φ 1.5	φ 3	70	5000 - 8000	13000	18
	CH-PO-5B	φ 5	φ 1.5	φ 3	70	5000 - 8000	12000	18
	CH-PO-6B	φ 6	φ 1.5	φ 3	70	5000 - 8000	10000	18
#220 (Gray)	CH-PM-3B	φ 3	φ 1.5	φ 3	70	5000 - 8000	15000	18
	CH-PM-4B	φ 4	φ 1.5	φ 3	70	5000 - 8000	13000	18
	CH-PM-5B	φ 5	φ 1.5	φ 3	70	5000 - 8000	12000	18
	CH-PM-6B	φ 6	φ 1.5	φ 3	70	5000 - 8000	10000	18
	CH-PM-10B	φ 10	φ 1.5	φ 3	70	4000 - 5000	6000	18
	CH-PM-3B-L	φ 3	φ 1.5	φ 3	150	—	1000	18
	CH-PM-4B-L	φ 4	φ 2.3	φ 2.3	150	—	3000	19
	CH-PM-5B-L	φ 5	φ 2.3	φ 2.3	150	—	3000	19
	CH-PM-6B-L	φ 6	φ 2.3	φ 2.3	150	—	3000	19
	CH-PM-10B-L	φ 10	φ 2.3	φ 2.3	150	—	2000	19

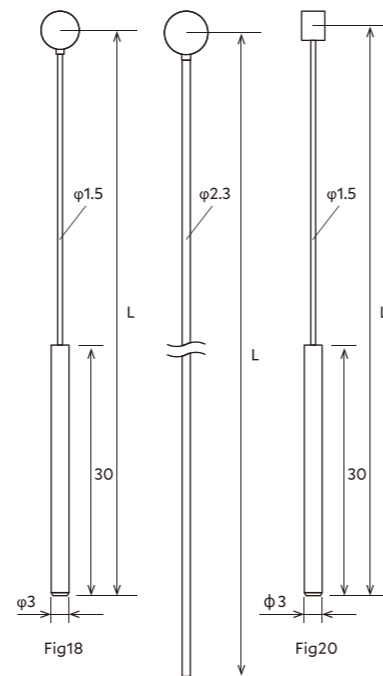

Cylinder type

Equivalent grit (Color)	Product code	Head size (mm)	Shaft diameter (mm)	Shank diameter (mm)	Overall length L (mm)	Standard rotational speed (min ⁻¹)	Maximum rotational speed (min ⁻¹)	Fig
#800 (Blue)	CH-PB-3R	φ3×3	φ 1.5	φ 3	70	5000 - 8000	15000	20
	CH-PB-4R	φ4×4	φ 1.5	φ 3	70	5000 - 8000	13000	20
	CH-PB-5R	φ5×5	φ 1.5	φ 3	70	5000 - 8000	12000	20
#400 (Orange)	CH-PO-3R	φ3×3	φ 1.5	φ 3	70	5000 - 8000	15000	20
	CH-PO-4R	φ4×4	φ 1.5	φ 3	70	5000 - 8000	13000	20
	CH-PO-5R	φ5×5	φ 1.5	φ 3	70	5000 - 8000	12000	20
#220 (Gray)	CH-PM-3R	φ3×3	φ 1.5	φ 3	70	5000 - 8000	15000	20
	CH-PM-4R	φ4×4	φ 1.5	φ 3	70	5000 - 8000	13000	20
	CH-PM-5R	φ5×5	φ 1.5	φ 3	70	5000 - 8000	12000	20
	CH-PM-5R-C01	φ5×10	φ 1.5	φ 3	70	5000 - 8000	12000	20

Precautions for Use

- The tool will be damaged when:
- processed beyond the maximum rotation speed
 - used with a pneumatic tool

Disc type

Equivalent grit (Color)	Product code	Head diameter x thickness (mm)	Maximum rotational speed (min ⁻¹)	Fig
#220(Gray)	CH-PM-14D	φ14×2	5000	21

Trial set

The set includes a disc type Stone and a shaft.

Product code	Product code
CHPM14D-SET	RMP3024X

φ2.3 to φ3 Collet Adapter
Adapts the φ2.3 shaft to fit on a rotary tool that can hold φ3 shanks.

Product code	Shaft diameter (mm)	Overall length (mm)	Mounting screw	Maximum rotational speed (min ⁻¹)	Fig
CH-D-SH	φ2.3	78	M2×6	5000	22

Precautions for Use

Use the disc type by normal rotation (clockwise). If it is used by reverse rotation, the screw will be loosened, and the Stone can be fallen off.

- The tool will be damaged when:
- processed beyond the maximum rotation speed
 - used with a pneumatic tool

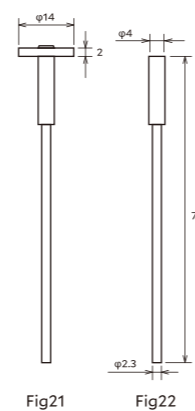

Applications

Deburring of a pipe part for aircraft (cross hole)



Material : SUS
Previous process : Drilling
Tool : CH-PM-6B

Before

Deburring with a rubber grinding stone on a rotary tool. Finish quality varied depending on the workers' skill. It took 40 min to remove burrs from 16 cross holes.

After

Remove burrs by contouring by inserting the Stone in the cross holes and pulling it out. Finish quality is uniformed, and deburring time is shortened.

Deburring of a hole in a groove

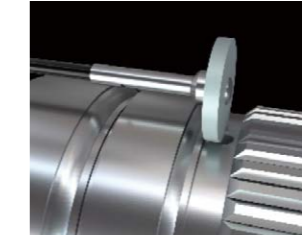

Material : SCM
Previous process : Drilling
Tool : CH-PM-145D

Before

Deburring with a disk-shaped grinding stone with a shaft. It was difficult to approach the spot with the shaft too short and the tool had a short life.

After

Easy to approach the groove with the disc type Stone with a long shaft. Compared with the grinding stone that was used before, the ceramic fiber Stone lasts longer and does not need to be replaced as frequently. Improved cost efficiency as only the stone need to be replaced.

How to use

All surfaces of the ceramic stone is abrasive and all of them can be used for deburring and polishing.

Ball type



Cylinder type

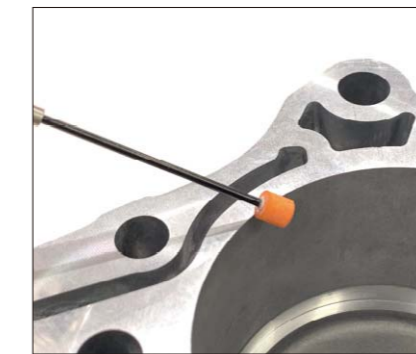

Disc type

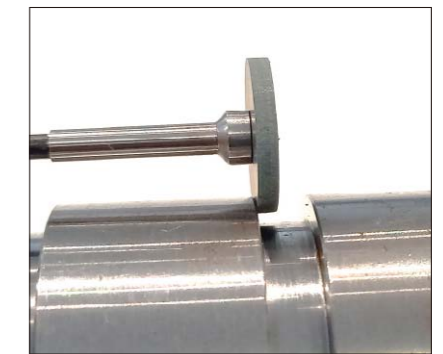

Features

The spring steel flexible shaft absorbs vibrations which makes soft contact with the surface possible while preventing the Ceramic Stone to bounce around, thereby reducing the risk of scratching the workpiece. These benefits make this an optimal tool for polishing and deburring areas that are deep inside the workpiece.

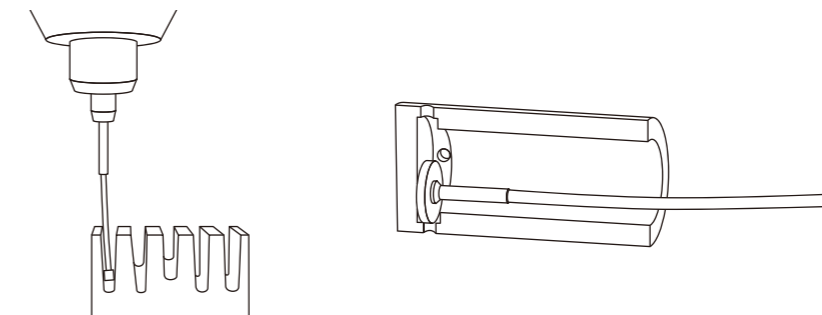

Instruction manual

XEBEC Stone™ Mounted Point

Suitable for use with pneumatic tools at high rotational speed

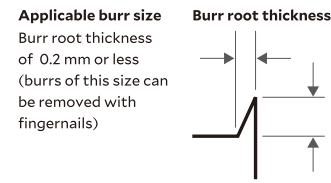

Video (YouTube)

Applicable equipment

This tool can be mounted on a rotary tool.

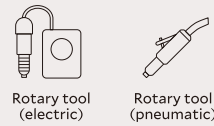

Equivalent grit (Color)	Product code	Head Size (mm)	Shank diameter (mm)	Head length (mm)	Overall length (mm)	Maximum rotational speed (min ⁻¹)	Fig
#220 (Gray)	AX-PM-3R	φ 3	φ 3	20	48	60000	23
	AX-PM-5RF	φ 5	φ 3	8	48	30000	24
	AX-PM-6T	φ 6	φ 3	20	48	60000	25

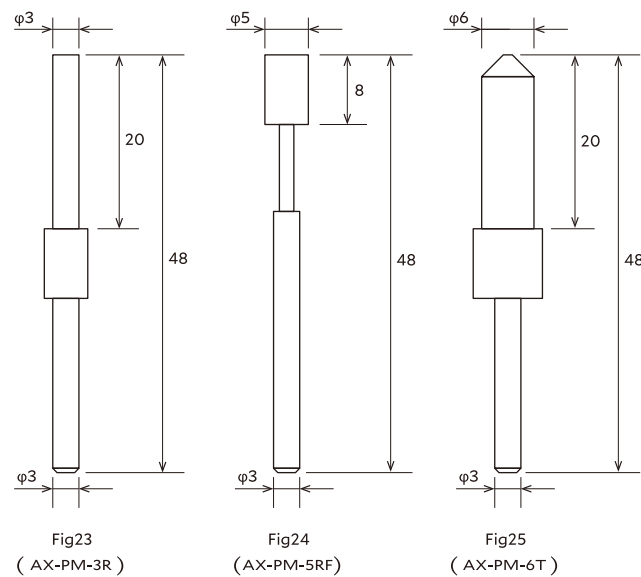

Applications

Deburring of edges

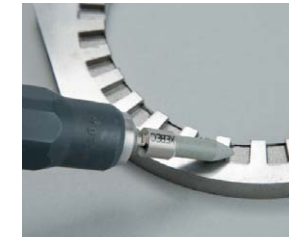

Before
A file was used for deburring, but it caused secondary burrs and a quality problem.

Material : SUS
Tool : AX-PM-6T

After
Secondary burrs are not formed. Improved the edge quality.

Deburring of parting lines



Before
A rotary bar was used because the burrs are large, but there was a safety problem.

Material : Aluminum
Tool : AX-PM-6T

After
Safety improved thanks to the abrasive stone. Improved work efficiency with high grinding power.

How to use

All surfaces of the ceramic stone is abrasive and all of them can be used for deburring and polishing. Capable of withstanding high speed, it can be used with pneumatic rotary tools in addition to power rotary tools.



Instruction manual

Mobile Micromotor System

Battery-powered rotary tool that is useful at workstations where power supply is unavailable. The handpiece is ultra-lightweight, ideal for manual operation without causing fatigue.



Product code	For use with	Maximum rotational speed (min ⁻¹)	Standard components
M2P33STX	φ3mm shank	30000	Handpiece with stand, controller ON/OFF foot switch, power cable for charging

*Run length: about 5 hours by continuous use

Technical Information

XEBEC Brush™ Surface

How to select

Refer to the charts below and select the brush color based on the workpiece material, burr root thickness and surface roughness.

Deburring

Workpiece material	Resin	Copper / Brass		
		Aluminum		
Burr thickness		General steel		
			Stainless steel	
			Heat-resistant steel	
			Cast-iron	
			Hard-to-cut material	
Brush (Color)	A13(Pink)	A11(Red)	A21(White)	A32(Blue)
	Grinding power → High			

Cutter mark removal and polishing

Workpiece material	Copper / Brass			
	Aluminum			
Achievable Surface roughness	General steel			
			Stainless steel	
			Heat-resistant steel	
			Cast-iron	
			Hard-to-cut material	
Brush (Color)	A13(Pink)	A11(Red)	A21(White)	A32(Blue)
	Grinding power → High			

If burrs remain

If burrs remain even when the Brush is used for burrs in applicable size with recommended depth of cut, please try the followings:

1. Increase rotational speed

Increase the rotational speed to the maximum.

Brush size (mm)	Product code	Standard rotational speed (min ⁻¹)	Maximum rotational speed (min ⁻¹)
φ 6	A13-CB06M, A11-CB06M, A21-CB06M, A32-CB06M	8000	10000
φ 15	A13-CB15M, A11-CB15M, A21-CB15M, A32-CB15M	4800	6000
φ 25	A11-CB25M, A21-CB25M, A32-CB25M	4000	5000
φ 40	A11-CB40M, A21-CB40M, A32-CB40M	2400	3000
φ 60	A11-CB60M, A21-CB60M, A32-CB60M	1600	2000
φ 100	A11-CB100M, A21-CB100M, A32-CB100M	960	1200
φ 125	A11-CB125M, A21-CB125M, A32-CB125M	800	1000
φ 165	A11-CB165M, A21-CB165M, A32-CB165M	600	750
φ 200	A11-CB200M, A21-CB200M, A32-CB200M	480	600

2. Check the rotational direction of the Brush

For horizontal burrs, up cut is recommended so that the brush tip pushes up the burrs.

3. Change the Brush color

Change the Brush with higher grinding power.
The grinding power of the Brush: Blue > White > Red > Pink
Make sure to select Brush color based on the workpiece material and burr root thickness.

If the edge is too rounded

Since the Brush rubs off the edge, it is not possible to remove burrs without rounding the edge (make a sharp edge).
To improve edge sharpness, please try the followings:

1. Increase feed rate

To make a sharp edge, increase the feed rate in 1,000 mm/min increments within the range where burrs can be removed.
Increasing the feed rate also helps to reduce the cycle time.

2. Decrease rotational speed

Decrease the rotational speed in 10 to 20% increments within the range where burrs can be removed.

3. Check the Brush color

The grinding power of the Brush: Blue > White > Red > Pink
Select Brush color based on the workpiece material and burr root thickness.

Reference data : Tool life

Material : Aluminum die-casting
Previous process : Face milling
Burr root thickness : 0.1 mm
Traveling distance : 1000 mm/pcs

Tool : A11-CB25M
Rotational speed : 4000 min⁻¹
Feed rate : 2400 mm/min
Depth of cut : 1 mm
Used length : 50 mm out of 75 mm

Tool life:
10 km
10,000 pcs (10 km/1000 mm)

* Tool life significantly varies depending on processing conditions, burr conditions (size and direction) and workpiece material.
The above data is not guaranteed. Please use as a guide.

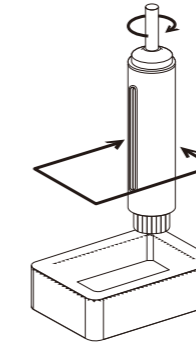

Material : Carbon steel S45C
Previous process : End milling
Burr root thickness : 0.1 mm
Traveling distance : 200 mm/pcs

Tool : A21-CB25M
Rotational speed : 4000 min⁻¹
Feed rate : 2000 mm/min
Depth of cut : 0.5 mm
Used length : 50 mm out of 75 mm

Tool life:
3 km
15,000 pcs (3 km/200 mm)

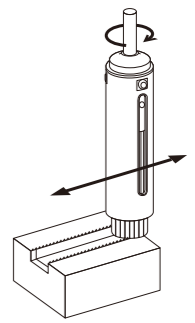

If the surface roughness worsens

Select the appropriate Brush

Check the Brush color

The ability to improve surface roughness is inversely proportional to the grinding power, meaning that A13 (Pink) achieves the best surface roughness, followed by A11 (Red), A21 (White), and A32 (Blue).
Make sure to select the appropriate Brush color based on the workpiece material and the target surface roughness.

Reference data : Surface roughness after deburring

	A11 (Red)	A21 (White)	A32 (Blue)
A5052	Approx. Ra 0.6 μm, Rz 5.0 μm	—	—
S50C	—	Approx. Ra 0.2 μm, Rz 1.6 μm	—
SUS304	—	—	Approx. Ra 0.3 μm, Rz 2.4 μm

To improve surface roughness

Select the appropriate Brush

1. Check the Brush color

The ability to improve surface roughness is inversely proportional to the grinding power, meaning that A13 (Pink) achieves the best surface roughness, followed by A11 (Red), A21 (White), and A32 (Blue).
Make sure to select the appropriate Brush color based on the workpiece material and the target surface roughness.

3. Increase the number of passes

When comparing in the same cycle time, increasing the number of passes makes bigger difference than decreasing feed rate.

2. Wet machining

The tool can be used for both dry and wet (oil-based and water-soluble) machining.
Wet machining may improve surface roughness and tool life.

Example

Rotational speed : 4000 min ⁻¹ Depth of cut : 0.5 mm Feed rate : 600 mm/min Number of pass : 1	➔	Rotational speed : 4000 min ⁻¹ Depth of cut : 0.5 mm Feed rate : 1200 mm/min Number of passes : 2
---	---	--

XEBEC Brush™ Surface End Type

How to select

Refer to the chart below and select the brush color based on the workpiece material and burr root thickness.

Workpiece material	Resin	Copper, brass		
		Aluminum		
		General steel		
			Stainless steel	
			Heat-resistant steel	
			Cast-iron	
			Hard-to-cut material	
Burr thickness	Micro fine burrs			
		Burr root thickness (≤ 0.1 mm)		
Achievable Surface roughness	$\leq Ra 0.1\mu m$			
		$\geq Ra 0.1\mu m$		
Brush (Color)	A13(Pink)	A11(Red)	A21(White)	A32(Blue)
Grinding power	→ High			

XEBEC Brush™ Crosshole

How to select

Refer to the chart below and select the brush color based on the workpiece material and burr root thickness.

Workpiece material	Resin	Copper, brass
	Copper, brass	Stainless steel
	Aluminum	
		Heat-resistant steel
		Cast-iron
		Hard-to-cut material
Burr thickness	Micro fine burrs	
		Burr root thickness (≤ 0.1 mm)
Achievable Surface roughness	$\leq Ra 0.1\mu m$	
		$\leq Ra 0.1\mu m$
Brush (Color)	A12(Red)	A33(Blue)
		A34(Dark blue)
Grinding power	→ High	

If burrs remain

If burrs remain even when the Brush is used for burrs in applicable size with recommended rotational speed, please try the followings:

1. Check the Brush color.
2. Increase the rotational speed to the maximum.
3. Increase the number of pass.
4. Decrease the feed rate.

To extend tool life

If tool life is short even when the brush is used for burrs in applicable size, please try the followings:

1. Decrease the rotational speed.
2. Increase the feed rate.

Reference data : Tool life

Material: Carbon steel S45C
 Previous process: Drilling
 Burr root thickness: 0.1 mm
 Hole diameter:
 Main bore $\Phi 10$ mm
 Cross hole $\Phi 5$ mm

Tool: CH-A12-5M-TL
 Rotational speed: 10000 min⁻¹
 Feed rate: 300 mm/min
 Depth of cut: 1 mm
 Used length: 10 mm out of 50 mm

Tool life: 4500 holes

* Tool life significantly varies depending on workpiece material and processing conditions. The above data is not guaranteed. Please use as a guide.

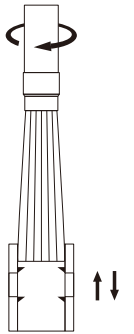

XEBEC Brush™ Surface Wheel Type

If burrs remain

If burrs remain even when the Brush is used for burrs in applicable size with recommended depth of cut, please try the following:

Increase the feed amount in 10 to 20% increments

To extend tool life

If the tool life is short even when the Brush is used for burrs in applicable size with recommended depth of cut, please try the following:

Increase the feed rate in 10 to 20% increments

Reference data : Tool life

Material: Carbon steel S45C
Previous process: End milling
Burr root thickness: 0.1 mm
Traveling distance: 120 mm/pcs

Tool: W-A11-50
Cutting speed: 250 m/min
(Rotational speed: 1600 min⁻¹)
Feed per bundle: 0.7 mm/bundle
(Feed rate: 7000 mm/min)
Depth of cut: 0.2 mm
Used length: 10 mm out of 13.5 mm

Tool life:
600 m
5000 pcs (600 m/120 mm)

* Tool life significantly varies depending on workpiece material and processing conditions.
The above data is not guaranteed. Please use as a guide.

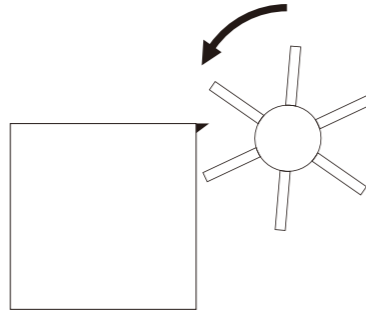

XEBEC Floating Holder™

Maintenance

Schedule a regular maintenance of cleaning and greasing sliding parts to ensure smooth movements and functioning. Recommended grease: Lithium soap grease (NLGI Grade #2).

- Please make sure to read the instruction manual before use.
- In order to ensure safety, be sure to observe the operator safety measures and operational precautions listed below.

Precautions here in described are made available for the products to be used safely and to prevent injuries and/or damages from occurring to others. In order to specify the level of severity and urgency, they are classified as “warning” and “caution”. Be sure to observe the contents as all are related to safety.

“Warning”: Those with the potential to cause death or serious injury to people or to occur property damage if handled improperly.

“Caution”: Those with the potential to cause injuries to people or to occur property damage if handled improperly.



Warning

Operator Safety Protection

[Use of protective equipment]

Wear safety glasses, protective gloves and masks when processing the tool. Wear clothing with long sleeves or other clothing that does not expose the skin, and fasten the cuffs and hems tightly.

[Use of protective cover]

Install covers on the machine tool and special-purpose machine, and use them while they are protected safely with the covers. Implement sufficient safety measures in order to ensure one's physical safety in the unlikely event of fragments scattering.

[Beware of cutting particles]

Cutting particles and burrs may scatter within the work area as the brush rotates; please stay clear of this area.

[Caution to your surroundings]

The work area is hazardous in case fragments or cutting particles scatter, enclose the work area to prevent other people from entering, or have people around the area wear protective equipment.

If these safety measures are neglected, there are following risks.

- Fragments and/or cutting particles can get into the eyes and cause loss of sight in the worst case.
- Fragments and/or cutting particles pierce skin of workers and cause injury.
- Dust generated from processing can cause lung damage, irritate skin, and bring on allergic reactions.



Cautions

Be sure to collect dust during processing and clean thoroughly after processing.

If the dust collection and cleaning are insufficient, dust may adversely affect the sliding parts of machine.

Precautions for use

Perform test operation for 1 minute or more before starting work, and for 3 minutes or more after the machine tool or product was changed. Check that there is no looseness and vibration. Stop the operation immediately with any sign of abnormality of the machine and the part where the product is installed.

There is the risk of operator loss of sight or injury resulting from the product detaching from the processing equipment, bristles breaking off, workpieces breaking, etc.

Stop the operation immediately with any sign of abnormality such as vibration while in use.

There is the risk of operator loss of sight or injury resulting from the product detaching from the processing equipment, bristles breaking off, workpieces breaking, etc.

Never use at a rotational speed exceeding the maximum rotational speed.

Make sure to set the processing conditions based on the instruction manual. Usage over maximum rotational speed may result in not only breakage of tools, machines and workpieces but also blindness or injury.

Usage over maximum rotational speed may cause the risk of operator loss of sight or injury resulting from bristles breaking off, workpieces breaking, etc.

About XEBEC

Beautiful deburring

Since 2002, XEBEC has been proposing “Automation of Deburring” worldwide.

Today, we are challenging to minimize lead time which takes to solve deburring problems as close to zero by making the best of our knowledge and experiences.

“Change the myth of deburring enhance the value of the finishing process.”

“Creating the world where people can use their talent in creative fields.”

This is what XEBEC will strive for.

XEBEC's 3 innovations

Technology Innovation	In order to provide essential and overwhelming solutions, we will continue technological innovation through the integration of scientific technologies, from material to software and hardware.
Process Innovation	We will continue to offer the best and innovative methods beyond the established concepts for all business such as marketing, manufacturing, sales and delivery.
Precision Management	We will continue to focus on quality and precision management in all aspects, including consistent product quality, shipping accuracy and swift and careful customer support.

Corporate Outline

Corporate Name	XEBEC TECHNOLOGY CO.,LTD.	Location	Head Office Fuerte Kojimachi1・7 Building 4F, 1-7-25, Koujimachi, Chiyoda-ku, Tokyo, 102-0083, Japan
Incorporated	June 3, 1996		
Main Business	Development, manufacturing and sales of industrial tools for deburring, polishing, chamfering, and surface finishing.		TEL.+81-3-3239-3481 FAX.+81-3-5211-8964
Capital	99 million Japanese Yen		
President & CEO	Norihiko Sumiyoshi		

History

